

Inventors: ZAMBONI RACHED MICHEL, RECAMI ERASMO, HERNANDEZ FIGUEROA HUGO E., et al.

METHOD AND APPARATUS FOR PRODUCING *STATIONARY* (intense) WAVE FIELDS OF ARBITRARY SHAPE

BACKGROUND OF THE INVENTION

The invention relates to a method for producing a stationary (intense) wave field of arbitrary longitudinal shape and high transverse localization.

Since many years it has been known that suitable frequency superpositions of Bessel beams, with the same phase velocity, yield localized wave pulses. Such pulses possessed the surprising characteristic of resisting the diffraction effects during their propagation.

In US 5,081,995 Lu has shown that it is possible to produce a non-diffracting series of (acoustic) pulses by using a piezoelectric transducer consisting in a series of rings. The piezoelectric transducer produces ultrasonic pulses used to increase the field resolution. The use of annular transducers is common, since axial symmetry is convenient for reducing diffraction in the generated wave fields.

Optical laser-light Bessel beams have been generated by Durnin et al. with a very simple experimental apparatus comprising a laser beam source, an annular slit, and a lens. A gaussian beam generated by the laser beam is transformed into a Bessel beam which is highly non-diffracting.

It would be of high technical relevance if a wave field could be generated, possessing not only a highly non-diffracting behaviour (i.e., being radially confined relatively to the direction of propagation), but also being confined within a predetermined space-region limited both in its direction of propagation and in its transverse direction. In this situation, inside the interval $0 \leq z \leq L$, at least one 3-dimensional space-

regions can be defined, having a predetermined size $L_1 \leq z \leq L_2$ within the said interval $0 \leq z \leq L$, so that the field is therein confined, and negligible outside it. Of course, since the method uses Fourier-type transformations, the same pattern a priori gets repeated inside each successive interval $L \leq z \leq 2L$, etc., unless the depth-field of each Bessel beam entering the superposition considered in the disclosed method is chosen to be not much greater than L .

Document QING CAO ET AL: "Axially symmetric on-axis flap-top beam" JOURNAL OF THE OPTICAL SOCIETY OF AMERICA A (OPTICS, IMAGE SCIENCE AND VISION) OPT. SOC. AMERICA USA, vol.17, no. 3, March 2000 (2000-03), pages 447-455, XP002305056 ISSN:0740-3232, describes a method for building a flat-top beam which is a square-shaped wave field having a width L . The starting point of the disclosed method is the Fourier integral of the Fourier Transform

$$\varphi(S) = \int_{-\infty}^{\infty} \sqrt{I_g(o, z)} \exp(i2\pi Sz) dz \quad \text{and its inverse function} \quad \int_{-\infty}^{-S_j} \varphi(S) \exp(-i2\pi Sz) dS .$$

This method making use of the traditional Fourier Integrals the disclosed method need to use values of S which runs also over negative values.

Furthermore the method disclosed in the above mentioned publication uses also a Fourier-Bessel transform. As it is well known Bessel beams constitute a base which can be used to express any function. In the disclosed method integrals running over positive values of S only since the Fourier-Bessel transform cannot accept negative values of the integration variable and integrals running also over negative values of the integration variable are mixed together. This approximation is justified as mentioned in the document only if the shift-term S could tend to infinity. However the paraxial approximation assumed in the above cited document is known as hold only for small values of S . Thus the method disclosed in the above cited publication is limited to configurations of the beam shape and dimensions for which the paraxial approximation is valid. For cases for which the paraxial

condition is not met the authors are obliged to carry out numerical simulations. The approximate numerical simulation taught in the above publication aims only to the production of a flat-top beam and the document does not teach how to evaluate amplitudes and phases of the Bessel beams by a closed-form equation and not even by general numerical procedures. Only a hope of generalisation of the disclosed approach is expressed by the authors.

Thus principally due to the fact that the disclosed method according to the above publication is limited by the role of the negative values of S and by the condition of the paraxial approximation this disclosed method does not allow a general treatment which is based on exact analytical equations which allow a complete control of all the parameters entering into play and of their experimental effects for producing in a simple way and without any approximation a stationary localized wave-field with an a-priori determined arbitrary shape.

A first target of the present invention is to provide a method for generating spatially confined stationary wave fields with any arbitrary (longitudinal) shape in correspondence with a segment of the type $0 \leq z \leq L$, quantity L being a periodicity interval which overcomes the drawbacks of the known methods.

A second aim is to provide a method for producing a source which generates the above-said spatially confined stationary wave field.

A further object of the present invention is to provide for an apparatus for generating a spatially confined stationary wave field.

SUMMARY OF THE INVENTION

The invention is based on the fact that suitable superpositions of Bessel beams, can yield stationary wave fields with high transverse localization, and with an arbitrary longitudinal shape. These superpositions of Bessel beams are particularly suitable when they have the same frequency. They are

new solutions of the wave equation, and may be called "Frozen Waves" (FWs). They are created with any arbitrary shape inside a spatial region corresponding to a longitudinal segment of the type $0 \leq z \leq L$, and their general "envelope" does not propagate. Moreover, their shape can be such that the stationary field is concentrated only within one or more (small) portions defined herein as sub-envelopes, $L-1 \leq z \leq L-2$ (of the interval $0 \leq z \leq L$), while a negligible field is expected to exist before or after the said envelope or sub-envelopes of the stationary field. Inside the said envelope or sub-envelopes a plane carrier wave is propagating, as it will be disclosed with greater detail in the following description; while the said envelope or sub-envelopes remain stationary

According to the invention, other eigenfunctions of the transverse laplacian operator can be used *different* from Bessel beams. For instance, stationary fields (FWs) can be obtained by the superpositions furnished by the disclosed method, provided that the said eigenfunctions yield a constant value (the same for all of them) along the z -axis. In such a case, the method allows defining a Fourier series for $\rho=0$ with the same coefficients A_n furnished by the method in the Bessel Beams case.

As it will become evident from the following description, such waves can be used in a great variety of applications, ranging from optical or electromagnetic tweezers to laser-type surgery and optical or ultrasound lancets, from micro-lithography to ultrasound or electromagnetic thermo-therapy of tumors, from jamming electromagnetic regions (balls) to a new kind of effective holography, from ultrasound kidney stone fragmentation to other ultrasound applications, etc.

The present invention refers to a method for producing a stationary **localized** wave field with **an a-priori predetermined** arbitrary longitudinal shape, inside a periodicity interval $0 \leq z \leq L$, and with high transverse localization, and the apparatuses accordingly designed. Namely, from a general point of view, this invention provides a method for producing a stationary **localized**

wave field of an a-priori predetermined arbitrary shape, comprising the following steps:

a) defining at least a volume being limited in the direction of the axis z of propagation of a beam, along a certain longitudinal interval $0 \leq z \leq L$;

b) defining a priori within the said longitudinal interval an intensity pattern $|F(z)|^2$ describing the desired localized and stationary wave field which function $F(z)$ is represented by means of a discrete Fourier Series or by a similar expansion in terms of ~~be approximated by means of a~~ (trigonometric) orthogonal functions; ~~or in particular Fourier expansion;~~

c) providing a discrete, generic superposition of Bessel beams or other highly transversally confined beams;

d) calculating the maximum allowed number of superimposed Bessel beams to be superposed;

e) calculating the amplitudes, and the phase velocities of each Bessel beam of the superposition, as well as and the transverse and longitudinal wavenumbers of each Bessel beam of the superposition, needed to obtain the predefined STATIONARY intensity pattern (within the predefined longitudinal interval);

f) recognizing and controlling the effect of each of the said parameters under point e) for controlling the longitudinal shape of the stationary localized wave field.

According to the present method also a partial control of the transversal shape of the stationary wave field is carried out by superposing for instance high order Bessel beams.

Thanks to the fact that the above method is based on exact analytical equations the method according to the invention allows a complete control of all parameters entering into play and of their experimental effects for producing in a simple way and without any approximation a stationary localized wave field with an a-priori predetermined arbitrary shape. The method according to the invention allows to exercise a complete control of the longitudinal shape and at least a partial control of the transverse shape of the stationary wave-field.

The method according to the invention has the great advantage that it can be translated in a experimental device with which each relevant parameter for controlling the longitudinal and transverse shape of the stationary wave field can be influenced by simple settings of the constructive aspects of the said device.

Once a shape is chosen the methdo according to the present invention allows to evaluate a priori the amplitude, the phase velocity, the relative phases and the transverse and longitudinal wave numbers of each Bessel beam of the superposition, simultaneously recognizing and controlling the effect of eache one of the parameters entering into play in order to obtain a total control of the longitudinal shape of the stationary wave field and by superposing high order Bessel beams even a partial control of the transverse shape of the stationary wave field.

The method requires to fix the volume of space wherein the stationary wave field has to be confined, and the stationary field itself by means of a trigonometric series, and then to define amplitude, and the other parameters (velocity or axicon angle, and phase) of each single Bessel beams entering the mentioned superposition of Bessel beams which provides the mathematical description of the desired stationary wave field. No limitation exists relatively to the kind of the considered waves. So the method associated with this invention can be applied to any kind of waves, like electromagnetic waves, acoustic waves (including sysmic or geophysical waves, and in general mechanical waves), and also gravitational waves, and so on.

In a particular embodiment of the method according to the present invention the method considers only the superposition of Bessel beams having the same frequency.

Nevertheless also a superposition of Bessel beams having different frequencies within a certain frequency bandwith or a superposition of Bessel beams which pulsed can lead to a STATIONARY (intense) wave field

Within a part of the present invention, a method for producing a source, which is suitable for generating such stationary and spatially confined wave fields, is also suggested.

In its general definition, the mentioned method for producing a source comprises the following steps:

providing one source for a single Bessel beam;

generating an array of many (more than one) of the said sources of Bessel beams;

configuring each source, of the said array of Bessel beam sources, according to amplitude, phase, longitudinal and transverse wavenumbers, and relative phase of each one of the Bessel beams of the superposition for

method in order to yield the stationary wave field described above.

As seen above, the proposed method allows designing, once predefined the desired behaviour of the field, the transducers able to produce such a field with a very high approximation (limited by the number of the said Bessel beam sources, which cannot be more than $2N+1$, where N is the maximum number of Bessel beams entering the superposition considered by the present invention. Indeed, the method is applied by suitably superposing Bessel beams and particularly, but not exclusively Bessel beams of the same frequency, and calculating relative phase and amplitude and wavenumbers of each of the N Bessel beams entering the desired superposition.

The invention provides also several embodiments of different devices and several methods applying the above-mentioned localized stationary wave fields, which are described in greater detail in the following description and in the annexed claims.

DETAILED METHOD FOR GENERATING A LOCALIZED STATIONARY WAVE FIELD ACCORDING TO THE INVENTION

Let us start from the basic Bessel beam solution (with axial symmetry) of the wave equation:

$$\psi(\rho, z - c/\cos\theta t) = J_0\left(\frac{\omega}{c} \sin\theta \rho\right) e^{i\frac{\omega \cos\theta}{c}(z - \frac{c}{\cos\theta}t)} \quad (1)$$

On using the usual variables (ω, β, k_ρ) , where β e k_ρ are the longitudinal and transverse wavenumbers, and $\omega = c\beta/\cos\theta$, the Bessel beam writes

$$\psi(\rho, z, t) = J_0(k_\rho \rho) e^{i\beta z} e^{-i\omega t} \quad (2)$$

where

$$k_\rho^2 = \frac{\omega^2}{c^2} - \beta^2 \geq 0 \quad (3)$$

and

$$\frac{\omega}{\beta} > 0 \quad (4)$$

The conditions $\omega/\beta > 0$ and $k_\rho^2 \geq 0$ ensure forward propagation, with no evanescent waves, and physical behaviour to the Bessel function J_0 respectively.. In the case of electromagnetic waves, quantity c represents the ordinary speed of light in vacuum.

Now, let us consider the following superposition of Bessel beams with the same frequency ω_0 :

$$\Psi(\rho, z, t) = e^{-i\omega_0 t} \sum_{n=-N}^N A_n J_0(k_{\rho n} \rho) e^{i\beta_n z} \quad (5)$$

where n are integer numbers, A_n are constant coefficients, and $\beta_n, k_{\rho n}$ are the longitudinal and transverse wavenumbers (still to

be determined), respectively; where, for each n , the parameters $(\omega_0, k_{\rho n}, \beta_n)$ must satisfy Eq.(3).

Because of conditions (3) and (4), we must have

$$0 \leq \beta_n \leq \frac{\omega_0}{c} \quad (6)$$

Now, our goal is using Eq.(5) to obtain a predetermined longitudinal intensity pattern within the interval $0 \leq z \leq L$.

Let us suppose that the desired pattern in the interval $0 \leq z \leq L$ is given by a function $F(z)$. We know that in that interval we can expand function F in a Fourier series

$$F(z) = \sum_{m=-\infty}^{\infty} B_m e^{i \frac{2\pi}{L} m z} \quad (7)$$

where

$$B_m = \frac{1}{L} \int_0^L F(z) e^{-i \frac{2\pi}{L} m z} dz . \quad (8)$$

It would be natural to use $\beta_n = 2\pi n/L$ in Eq.(5), with $A_n = B_n$. HOWEVER this choice would imply negative values of β_n (backward waves), what is forbidden by our condition (4), because ω_0 is obviously positive.

To overcome this problem we write β_n as:

$$\beta_n = Q + \frac{2\pi}{L} n \quad (9)$$

where $Q > 0$ is a value chosen depending on the conditions of the given experimental situation. According to Eq.(6), we have

$$0 \leq Q \pm \frac{2\pi}{L} N \leq \frac{\omega_0}{c} \quad (10)$$

The inequation (10) determines the maximum value of n , that we call N , once we have chosen Q , L and ω_0 .

in this way, to obtain a longitudinal pattern of intensity approximately equal to the desired one, $F(z)$, in the interval $0 \leq z \leq L$, the solution (5) should be written as:

$$\Psi(\rho = 0, z, t) = e^{-i\omega_0 t} e^{iQz} \sum_{n=-N}^N A_n e^{i\frac{2\pi}{L}nz} \quad (11)$$

with

$$A_n = \frac{1}{L} \int_0^L F(z) e^{-i\frac{2\pi}{L}nz} dz \quad (12)$$

Obviously, we get only an approximation of the desired longitudinal pattern because the trigonometric series (11) has been truncated. The number of terms is defined, once the values of Q , L and ω_0 are chosen.

When $\rho \neq 0$, $\Psi(\rho, z, t)$ is

$$\Psi(\rho, z, t) = e^{-i\omega_0 t} e^{iQz} \sum_{n=-N}^N A_n J_0(k_{\rho n} \rho) e^{i\frac{2\pi}{L}nz} \quad (13)$$

with

$$k_{\rho n}^2 = \omega_0^2 - \left(Q + \frac{2\pi n}{L}\right)^2 \quad (14)$$

The coefficients A_n will give the amplitudes and the relative phases of each Bessel beam in the superposition.

Because we are adding together zero order Bessel functions, we can expect a high field concentration around $\rho = 0$.

BRIEF DESCRIPTION OF THE DRAWINGS

Figure 1 shows a comparison between the intensity of the desired longitudinal function $F(z)$ and that of the stationary wave field FW ("Frozen Wave"), $\Psi(\rho=0, z, t)$, obtained from Eq.(11)

Figure 2 shows a 3D plot of the field intensity of the localized stationary wave field (FW) chosen by us.

Figure 3 shows an orthogonal projection of Fig.2.

Figure 4 shows a comparison between the intensity of the desired longitudinal function $F(z)$, given by Eq.(16), and that of the localized stationary wave field, $\Psi(\rho=0, z, t)$, obtained from Eq.(11)

Figure 5 shows a 3D plot of the field intensity of the localized stationary wave field considered by us.

Figure 6 shows an orthogonal projection of Fig.5.

Figure 7 illustrates schematically the experimental apparatus adopted by Durnin et al. as a possible set-up for generating a Bessel beam.

Figure 8 illustrates a suitable, concentric annular slits array for generating a particular superposition of Bessel beams, and in particular a localized stationary wave field (FW) according to the invention.

Figure 9 illustrates schematically the experimental set-up constituted by laser beam, a set of annular apertures, and a thin lens.

Figure 10 illustrates a geometrical scheme of the previous experimental set-up in figure 9.

Figure 11 shows an example of a two-peak stationary wave field corresponding to a calculated set of slit-radius values.

Figure 12 shows an example of a single-peak stationary wave field corresponding to another calculated set of slit-radius values.

Figure 13 shows the longitudinal pattern of the localized stationary wave field obtained, according to the invention, from a superposition of 37 Bessel beams, corresponding to situation (1) i.e., to the optical case.

Figure 14 shows a schematic 3D image of the localized stationary wave field, obtained by superposition of 37 Bessel beams, corresponding to the optical case (situation 1 in the following).

Figure 15 is an orthogonal projection of Fig.13

Figure 16 depicts the same view of figure 12 in DB units.

Figure 17 shows the longitudinal pattern of the localized stationary wave field obtained, according to the invention, by superposition of 181 Bessel beams, corresponding to the optical case.

Figure 18 is a 3D view of the localized stationary wave field represented in Fig.17, obtained according to the invention by superposition of 181 Bessel beams, and corresponding to the optical case. Figure 19 is an orthogonal projection of Fig. 18.

Figure 20 shows the content of figure 18 in DB units.

Figure 21 illustrates the transverse behavior of one of the stationary wave field (obtained according to the invention) in the plane $z = z_f$.

Figure 22 shows the longitudinal pattern of the localized stationary wave field obtained, according to the invention, by superposition of 181 Bessel beams, corresponding to situation (2) which refers still to an optical case but with an increased spatial resolution of the localized stationary wave field.

Figure 23 is a 3D view of the localized stationary wave field represented in Fig.22, obtained according to the invention by superposition of 181 Bessel beams, and corresponding to situation (2)

Figure 24 is an orthogonal projection of Fig. 22

Figure 25 illustrates figure 22 in DB units.

Figure 26 shows a diagram of the transverse behavior of the localized stationary wave field of figures 22 to 25 in the plane $z = z_f$.

Figure 27 shows the longitudinal pattern of the localized stationary wave field obtained, according to the invention, by

superposition of 29 Bessel beams, and corresponding to situation (3) that is, to the microwave case.

Figure 28 is a 3D representation of the localized stationary wave field represented in Fig.27, obtained according to the invention by superposition of 29 Bessel beams, and corresponding to situation (3)

Figure 29 is an orthogonal projection of Fig.28

Figure 30 illustrates figure 27 in DB units

Figure 31 illustrates the longitudinal pattern of the localized stationary wave field obtained, according to the invention, by superposition of 181 Bessel beams, corresponding to situation (4) that is, to the acoustic case

Figure 32 is a 3D view of the localized stationary wave field represented in Fig.31, obtained according to the invention by superposition of 181 Bessel beams, and corresponding to situation (4) in the following: i.e., to the acoustic case

Figure 33 is an orthogonal projection of Fig.31.

Figure 34 illustrates Figure 31 in DB units.

Figure 35 illustrates the transverse behavior of the localized stationary wave fields corresponding to figures 31 to 34, in the plane $z = z_f$

Figure 36 illustrates the cross section of a stationary wave field according to the invention obtained by a superposition of Bessel beams of higher order.

Figure 37 illustrates schematically an embodiment of a laser cutting device operating according to the method of the present invention.

Figures 38a and 38b illustrates respectively a device for performing needle-less injections by applying the teachings according to the present invention.

Figure 39 is a schematic figure illustrating the case where inside a stationary envelope or sub-envelopes any kind of propagating wave can be generated and not only a plane wave: for example in such a way to generate a peak which is born on a first side of the envelop or sub-envelope and dies on the other side of

the said envelope or sub envelope, while a second peak appears on the said first side.

DETAILED DESCRIPTION OF THE DRAWINGS

EXAMPLES OF THE APPLICATION OF THE METHOD

In this section we shall give two examples of the theoretical method according to the present invention for constructing localized stationary wave fields the method for obtaining said localized stationary wave field being already described above.

For completeness' sake, let us notice that the method provides in general the approximated representation of the desired confined stationary wave field by means of a Fourier expansion (or a Fourier-Bessel expansion when ρ is different from zero) . This expansion can be of a kind more general than Fourier's. Although the examples use a Fourier series, it is important to notice that no limitation is set to the expansion or to the series to be used for approximating the desired spatially confined stationary wave field, provided that it is a *trigonometric* expansion.

The two following examples are brought hereinafter with numeric details.

First case:

Let us suppose that we want an optical wave field with $\lambda = 0.632\mu\text{m}$ ($\omega_0 = 2.98 \cdot 10^{15}$ Hz), whose longitudinal pattern (on its axis) in the range $0 \leq z \leq 0.5$ m is a step function with centre located at $z = 0.25$ m and with width $\Delta z = 0.1$ m. In other words, the desired function is given by:

$$F(z) = H(z - 0.2) - H(z - 0.3) \quad (15)$$

where $H(\cdot)$ is the step function.

With this, we can calculate the coefficients A_n , on inserting Eq. (15) into Eq. (12), and use them in the superposition given by our Eq. (13). Let us choose in this case $Q = 0.9999 \omega_0/c$; this choice allows a maximum value for n given by $N = 79$ (we can see this from Eq. (10)). However, we are not obliged to use $N = 79$, but we can use for N any value smaller than that calculated from Eq. (10). Of course, if we use the maximum value allowed to N , we will get a better result. In the present case we will adopt $N=10$, for which Eq. (20) furnishes a good enough approximation of the desired function. In Fig.1 the intensity of the desired longitudinal function $F(z)$ is compared with that of the localized stationary wave field indicated as FW which corresponds to $\Psi(\rho = 0, z, t)$, obtained from Eq. (11) by using $N = 10$.

A good agreement between the desired longitudinal behaviour and the localized stationary wave field approximation FW can be observed. Obviously we can improve the approximation by using bigger values of N .

In Fig.2 we show the 3D wave field intensity of the localized stationary wave field FW given by Eq. (13). It appears evident that this field has a good transverse localization and possesses the desired longitudinal pattern. The same figure is shown in Fig.3, but in an orthogonal projection.

Second case:

Here, let us suppose that we want an optical wave field with $\lambda = 0.632 \mu\text{m}$ ($\omega_0 = 2.98 \cdot 10^{15} \text{ Hz}$), whose longitudinal pattern (on its axis) in the range $0 \leq z \leq 0.5\text{m}$ consists in a pair of parabolas, whose centres are located at $z = 0.22 \text{ m}$ and $z = 0.28 \text{ m}$, with roots at $z = 0.2 \text{ m}$, $z = 0.24 \text{ m}$, $z = 0.26\text{m}$ and $z = 0.30 \text{ m}$. Outside the intervals $0.2 \leq z \leq 0.24 \cup 0.26 \leq z \leq 0.30$, we want the

function to have zero value. In other words, the desired function is given by:

$$F(z) = -(z - 0.20)(z - 0.24) \quad \text{for } 0.20 \leq z \leq 0.24$$

$$F(z) = -(z - 0.26)(z - 0.30) \quad \text{for } 0.26 \leq z \leq 0.30 \quad (16)$$

$$F(z) = 0 \quad \text{elsewhere}$$

Again, we can calculate the coefficients A_n by substituting Eq.(16) into Eq.(12), and use them in the superposition given by our Eq.(11). In the present case, we chose $Q = 0.9999\omega_0/c$: this choice allows a maximum value of n given by $N = 79$ (we can see this from Eq.(9)). But we adopt $N = 10$, for which Eq.(11) already yields a good approximation of the desired function.

Fig.4 shows the comparison of the intensity of the desired longitudinal function $F(z)$ with that of the localized stationary wave field approximation FW, $\Psi(\rho = 0, z, t)$, obtained from Eq.(11) with $N = 10$: A good agreement between the desired longitudinal behaviour and the localized stationary wave field FW can be observed. Obviously we can improve the approximation by using higher values of N .

Fig.5 shows the 3D wave field intensity of the localized stationary wave field approximation FW given by Eq.(13). We can see that this field has a good transverse localization and possesses the desired longitudinal pattern. The same figure is shown in Fig.6, but in an orthogonal projection.

THE SOURCE FOR GENERATING LOCALIZED STATIONARY WAVE FIELDS ACCORDING TO THE INVENTION

In accordance with the previous method for generating localized stationary wave fields, it is possible to construct solutions of the wave equation with the desired stationary longitudinal pattern on their axis within the range $0 \leq z \leq L$, and with a high transverse field concentration, just by making a

suitable superposition of Bessel beams. In the particular embodiment of the method described herein the superposed Bessel beams are Bessel beams having the same frequency. In this way, if any experimental *apparatus capable of generating a Bessel beam* is available, an array of such apparatuses can be used to generate a sum of Bessel beams with the appropriate (longitudinal) wavenumbers, amplitudes and phases, and by this array we can generate the stationary wave fields according to the invention.

It has to be noticed that the Bessel beams of the superposition can also be non monochromatic. For example the Bessel beams may be pulses having a certain bandwidth or the Bessel beams may also have different frequencies.

A first example of a source of a single Bessel beam can be constructed by using the very simple experimental apparatus of Durnin et al.. Such source is illustrated in figure 7.

Referring to fig. 7, as is well-known since the experiment by Durnin et al. in 1987, a very simple way to generate a Bessel beam is using an annular slit 10 located in the front focal plane of a convergent lens 11 and illuminated by a cw laser 12.

Let a be the radius of the annular slit, δa its thickness, λ the wavelength of the laser, and f and R focal length and radius of the lens, respectively. On illuminating the annular slit with a cw laser of frequency ω_0 , and provided that the condition $\delta a \ll \lambda f/R$ is satisfied, the Durnin et al.'s apparatus generates, after the lens, a wave field similar to a Bessel beam along a certain field depth, i.e., within a certain range of distance. Within this range, given by $0 \leq z \leq Z \approx R f/a$, the generated Bessel beam can be written as:

$$\psi(\rho, z, t) = \Lambda J_0(k_\rho \rho) e^{i\beta z} e^{i\omega_0 t} \quad (17)$$

with Λ constant depending on the values of a , f , ω_0 and

$$k_\rho = \frac{\omega_0 a}{c f} \quad (18)$$

and

$$\beta^2 = \frac{\omega_0^2}{c^2} - k_\rho^2 \quad (19)$$

Thus we can see that the transverse and longitudinal wavenumbers are determined by radius and focus of the slit and lens, respectively.

Once more, we recall that the wave field will approximately possess a Bessel beam behaviour in the range $0 \leq z \leq Z \approx Rf/a$, which we have called *field depth* of the Bessel beam in question.

As we have seen from the previous Sections, the localized stationary wave fields according to the invention are obtained by suitable superpositions of Bessel beams. So we can construct experimentally the localized stationary wave fields for instance by using several concentric annular slits as illustrated in Fig.8, where each radius is chosen to yield the correct longitudinal wavenumber, and where the transfer function of each annular slit is chosen in order to correspond to the coefficients A_n of Eq.(11), which are necessary for obtaining the desired longitudinal pattern.

To explain the above matter in greater detail, let us suppose that we have $2N + 1$ concentric annular slits with radii a_n , with $-N \leq n \leq N$. Along a certain range after the lens, we'll have a wave field given by the sum of the Bessel beams produced by each slit:

$$\Psi(\rho, z, t) = e^{-i\omega_0 t} \sum_{n=-N}^N \Lambda_n T_n J_0(k_{\rho n} \rho) e^{i\beta_n z} \quad (20)$$

where T_n are the possible transfer functions of each annular slit (regulating amplitude and phase of the emitted Bessel beams, and regarded as constants for each slit), while Λ_n are constants depending on the characteristics of the apparatus which can be approximately written as

$$\Lambda_n = \frac{a_n \omega_0 \exp\left[\frac{i\omega_0 a_n^2}{2cf}\right]}{2\pi c f i} \quad (21)$$

which is valid when δ_a is very small. The transfer functions can be determined experimentally or empirically. In optics for example by covering the annular slits by a superthin film or in acoustic by correspondingly exciting the transducers. An alternative way is to use additional lenses as it will be explained better in the following

Moreover, the transverse and longitudinal wavenumbers are given by

$$k_{\rho n} = \frac{\omega_0 a_n}{c f} \quad (22)$$

and

$$\beta_n^2 = \frac{\omega_0^2}{c^2} - k_{\rho}^2 \quad (23)$$

On the other hand, we know from our method that for constructing the localized, stationary wave fields we must have β given by Eq. (9):

$$\beta_n = Q + \frac{2\pi}{L} n$$

On combining together Eqs. (9,22,23), we get

$$\left(Q + \frac{2\pi}{L} n\right)^2 = \frac{\omega_0^2}{c^2} - \left(\frac{\omega_0^2 a_n}{c^2 f}\right)^2 \quad (24)$$

and solving with respect to a_n we obtain

$$a_n = f \sqrt{1 - \frac{c^2}{\omega_0^2} \left(Q + \frac{2\pi}{L} n\right)^2} \quad (25)$$

Equation (25) yields the radii of the annular slit that provide the correct longitudinal wavenumbers for the generation of the localized, stationary wave fields according to the invention. However, the procedure is not ended.

Once the desired longitudinal pattern $F(z)$ is chosen, in Eq. (13) we necessarily meet the coefficients A_n given by Eq. (12). Such coefficients must be the coefficients of Eq. (20). To obtain this, it is necessary that each annular slit has an appropriate

transfer function, which will regulate amplitude and phase of each Bessel beam emitted by the slits.

By using Eqs. (11,12,20) we obtain that the transfer function T_n of the n -th annular slit has to be:

$$T_n = \frac{A_n}{\Lambda_n} = \frac{1}{L \Lambda_n} \int_0^L F(z) e^{-i \frac{2\pi}{L} n z} dz \quad (26)$$

where Λ_n is given by Eq. (21).

Therefore, with the radius of each annular slit given by Eq. (25) and the transfer functions of each slit given by Eq. (26), we can obtain a localized stationary wave field FW that has the desired longitudinal behaviour in the range $0 \leq z \leq L$.

Obviously we have to guarantee that the distance L is smaller than the smallest Bessel beam field-depth among the Bessel beams in the superposition (20). In other words, we must have:

$$L \leq Z_{\min} \approx \frac{Rf}{a_{\max}} \quad (27)$$

where a_{\max} is the biggest radius of the concentric annular slits. In the following two experimental apparatuses are illustrated, which generate different localized stationary wave fields.

I. Experimental apparatus producing two intensity peaks

With regard to the annular ring mask, one can consider four concentric annular rings, with the following radii

$$a_1 = 1.099 \text{ mm}$$

$$a_2 = 1.253 \text{ mm}$$

$$a_3 = 1.386 \text{ mm}$$

$$a_4 = 1.504 \text{ mm} ,$$

all of them having the same thickness, $\Delta a = 10 \mu\text{m}$ (which is actually a limit value: higher values should not be used), and, for simplicity's sake, the same transfer function, equal to unity. In this situation, we chose a CW laser with $\lambda = 632.8 \text{ nm}$, and a thin lens with focal distance $f = 30.5 \text{ cm}$ and radius $R = 3.5 \text{ mm}$. With these parameters, peaks are produced at 31.5 cm and 63 cm:

II. *Experimental apparatus producing a single intensity peak*

With regard to the annular ring mask, one can consider 4 concentric annular rings, with the following radii

$$a_1 = 2.303 \text{ mm}$$

$$a_2 = 2.380 \text{ mm}$$

$$a_3 = 2.451 \text{ mm}$$

$$a_4 = 2.518 \text{ mm} ,$$

all of them *having the same thickness* $\Delta a = 10 \text{ }\mu\text{m}$. In this situation, we chose a CW laser with $\lambda = 632.8 \text{ nm}$, and a thin lens with focal distance $f = 30.5 \text{ cm}$ and radius $R = 3.5 \text{ mm}$. With these parameters, a peak is produced at 32 cm.

More in general, our method is able to yield a mathematical model, and the characteristics for design and construction of the source by using arrays of sources for Bessel beams.

According to a first embodiment of the said sources, a source for generating a superposition of Bessel beams, which is suitable for generating a localized stationary wave field in one or more confined space-regions, comprises at least one source beam generator: Namely, at least one diffraction pattern against which the entering monochromatic beam is directed, the diffraction pattern being created for instance by an array of coaxial annular slits. Radius and transfer function of each annular slit are related to the longitudinal wavenumber (and therefore with the transverse wavenumber too), to the amplitude, and to the phase of the Bessel beam to be generated by the said annular slit.

Furthermore a lens is provided *after* the array of coaxial annular slits, so that the array results to be located in the rear focal plane of the lens; the said lens correcting the phase of the waves impinging on it, and contributing to determine, together with the annular radius of each slit, the transverse, and longitudinal, wavenumber of the corresponding Bessel beam.

A single frequency is used. The kind of source beam and of the diffraction device and/or of the lens depends on the desired frequency range and type of waves. Till now the method has not been restricted to any particular kind of wave and thus it can be applied to any kind of waves existing in nature, such as for example: mechanical waves as acoustic waves or the like; electromagnetic waves such as light, or laser beams, or microwaves; or even gravitational waves, or waves describing elementary particles.

Let us explicitly recall that the transfer function of each annular source has to be produced either by suitably exciting the corresponding transducer, or, in the optical case, by covering each annular slit by the required super-thin film determining amplitude and phase of the Bessel beam generated by the said slit. Such a set of super-thin films, however, can be replaced by a set of supplementary lenses: Essentially, by a second lens, identical with the previous one, but *just*aposed to the diffracting array. Due to the action of the lens located immediately after the slit array, the transfer function T_n of each slit becomes a real quantity equal to A_n , at variance with the relation $T_n = A_n / \Lambda_n$, given by Eq. (26).

More specifically, the Transfer Functions of the annular slits provides the corresponding Bessel beam with the correct amplitude and phase. The transfer function T_n of the n -th annular slit must be given by Eq. (26), where Λ_n is the complex weight of the Bessel beam generated by the n -th slit when its transfer function is equal to 1. When δa is almost equal to zero, the value of Λ_n is given by Eq. (21). As already said, the transfer function T_n can be obtained by putting thin films on the surface of the n -th slit. The action of a thin-film is as follows: Let us consider an wave coming from a 1st medium, with refraction index n_1 , meeting (e.g.,

orthogonally) a film with width d and refraction index n_2 (which can be complex, due to absorption, $n_2 = N_2 + i \alpha$), and going on to a 3rd medium with refraction index n_3 . Meeting the film, the incoming wave is partially reflected and partially refracted (i.e., transmitted into the film). Inside the film multiple reflections take place, while each reflected wave in its turn is partially refracted and transmitted into the 3rd medium (and also into medium 1st, but this is of no interest for us). The total wave reaching the 3rd medium is the sum of the all the previous transmitted waves, and its amplitude and phase will depend on n_1 , $n_2 = N_2 + i \alpha$, n_3 , and d . In our case (air-film-air) $n_3 = n_1$, and we can choose N_2 , α , and d in order to get the desired amplitude and phase of the wave coming out from the film. One can even use a set of superposed thin-films, to increase the degrees of freedom, tunable so to obtain the desired effect. The transfer functions T_n can be generated in such a way. Going back to the invention, os coefficients A_n according to the method *must* be os coefficients of the Bessel beams generated by the apparatus considered in the invention. In the typical case of annular slits, if we do *not* cover them with a film, each slit generates a Bessel beam with a coefficient that has been called λ_n above in this patent. When we have, by contrast, a transfer function T_n for each slit (differing from slit to slit, but constant for each slit), the coefficient of the Bessel beam generated by the said slit becomes $T_n \lambda_n$: But we want such a coefficient to be A_n ; therefore, according to the method here disclosed it must be $T_n = A_n / \lambda_n$. *All such a procedure can be however facilitated* by adding an extra lens (with focal distance equal to that of the other lens) immediately after the plane of the slits: In this way as already mentioned the transfer functions T_n are made equal to λ_n (that is, $T_n = \lambda_n$), where λ_n are the coefficients of our superposition given

by Eq. (12), and can be rendered real numbers by suitable choices of $F(z)$ and the interval $0 \leq z \leq L$.

With regard to the behavior of the localized stationary wave field in media without losses, the theory of the stationary wave fields according to the present invention can furnish results similar to the free-space ones. This happens because the stationary wave fields according to the invention can be built up via suitable superposition of Bessel beams of the same frequency, so that there is no problem with the material dispersion.

However, in LOSSY MEDIA, some care is in order. Surprisingly, for Bessel beams the absorption coefficient in the direction of propagation depends on the longitudinal wavenumber, besides on the frequency. Consequently, each Bessel beam in the mentioned superposition will have a different attenuation in the longitudinal direction: This affects the structure of the localized stationary wave fields defined according to the above mentioned method, and some technical tricks can be accordingly used, as explained in the following.

An appropriate choice of the parameters can overcome the mentioned problem. We shall describe the behavior of the method at first in *lossless* media, mentioning afterwards *lossy* media.

LOCALIZED STATIONARY WAVE FIELDS IN LOSSLESS MEDIA

On using the above mentioned method and theory of the localized stationary wave fields, we can construct (as an example) a field with the desired longitudinal pattern inside a certain spatial interval: for instance, $0 \leq z \leq L$; so that it results spatially concentrated in the surrounding of a specific point. The residual intensity of this field will depend on the number of Bessel beams used to construct the localized stationary wave field. Namely, on the number of terms of the Fourier series that

will suffice for approximating the desired longitudinal intensity pattern.

Some field configurations require for example many Bessel beams in the superposition: It is the case in which the width of the localized stationary wave field is much smaller than its distance from the source.

The number of Bessel beams in the superposition is limited (according to the disclosed method) by the parameters Q , L , and by the experimental apparatus itself (besides the chosen frequency).

The original theory of the localized stationary wave fields (by M.Zamboni-Rached, E.Recami, et al.) supports the disclosed method by many more items than those that can be here exploited or employed.

Given a desired longitudinal pattern, there are many different methods to reproduce it by the theory. The choice of the best method depends on the limitations of the available apparatus, on the field nature or conditions, etc.

LOCALIZED STATIONARY WAVE FIELDS IN LOSSY MEDIA

In a lossy medium, each Bessel beam of the superposition furnished by the method will suffer a different attenuation coefficient α_n (corresponding to the Bessel beam with longitudinal wavenumber β_n). When multiplying each Bessel beam of the said superposition by its loss-factor $\exp[-\alpha_n z]$, the superposition is no longer a Fourier series, since the factors α_n are different. This is not a problem. Indeed, when using longitudinal coefficients approximately equal one to the other (as it is the case, in general), then the attenuation coefficients α_n will be almost equal, so to be all replaceable by their average value $\alpha = (\alpha_1 + \alpha_2 + \dots + \alpha_N) / N$. Then, all terms of the trigonometric series (defining the FW according to the method) result to be multiplied by the same, common factor $\exp[-\alpha z]$, which can be

taken out of the series: So that, according to the invention, one still get a Fourier series multiplied by the said constant factor; namely, $\zeta(\rho, z, t) = \exp[-\alpha z] * \exp[iQz - i \omega_0 t) * \text{Series}$, when * indicates ordinary multiplication, and Series is the ordinary Fourier-Bessel series furnished by the disclosed method. In conclusion, one can proceed according to the method, even if now the FW field will be attenuated over the distance due to the loss-factor $\exp[-\alpha z]$.

In other words, in lossy media with homogeneous characteristics, there will be no problem, except for the attenuation taking place with the distance.

In lossy media without homogeneous characteristics, however, also reflection will take place. If the media is layered in the sense of transmission with a symmetry plane for the interfaces, thus resulting in symmetry existing in refraction indexes, the method could again be applied.

If there is no evidence of any symmetry in refraction properties, it will be necessary to introduce the refraction index at any significant point through the media and numerically calculate according to the disclosed method the resulting final field.

As seen above, in homogeneous lossy media an energy reduction took place, the loss having an expression of the type $e^{-\alpha z}$. In this case --when the loss is of a limited amount, of the order e.g. of 10-20% of the total initial energy-- a compensation coefficient of the type $e^{+\alpha z}$ could be added in the superimposition, and the disclosed method could be applied accordingly in order to get again a stationary wave field similar to the one obtained in the case of lossless media according to the invention.

If the loss is greater than 50%, the Frozen Wave can be expected to vanish, as for a plane wave. In any case, the relation to express the loss behaviour can be simplified in the form

$I_L = I \exp[-\alpha z_f]$, where I is the FW peak intensity in the vacuum, I_L is the peak intensity in the lossy medium, and z_f is the FW peak position in vacuum for the same situation.

In analogy to the monochromatic wave propagation as used in the disclosed method, the phase velocity is changed but the phase will be unchanged, thus allowing a simple realization of the transducer even for these lossy conditions.

A further parameter influencing the modification in lossy media, is, however, the lossy media longitudinal extension L' . The FW peak according to the disclosed method could not be created, if the wave penetration is less than the distance between the emitter and the desired peak

In the following, a method and a technical solution based on the disclosed approach for some particular specific apparatuses and experimental setups are disclosed.

OPTICS AND MICROWAVES

Optical case: Situation (1)

Let us suppose that it is desired a (free space) optical field ($\lambda = 0.632\mu\text{m}$) in the interval $0 \leq z \leq 3\text{cm}$, with a spatial resolution of 1mm, localized around

$z = z_f = 1.5\text{cm}$. We can construct this field by using a parabolic function centered at z_f with width of 1.5mm. See Fig. 13, 14, 15 and 16 corresponding to this pattern. Figure 13 shows the 2D plot [line $F(z)$ is the desired field, while line FW is the actually obtained localized stationary wave field]. Fig.14 is

the 3D representation of figure 13, and Fig.15 its orthogonal projection. In Fig.16 we recast Fig.13 in decibel, to show the residual intensity in a more clear form.

In this case the source can be manufactured by using an array of annular slits. For the considered localized stationary wave field, the radii of such annular slits must have values of a few millimeters; we need moreover a lens with focal length of 10.5cm and an aperture of 1.5mm (*source size*). For instance, we can use 37 annular slits, with a minimum radius of 0.08mm (even zero, if one wants) and a maximum radius of 4mm. Other configurations would be however possible: the proposed configuration is based on an easily available apparatus for fabrication and economical considerations.

Reducing the residual intensity:

The residual intensity of this localized stationary wave field can be reduced. To do this, we need to increase the number of Bessel beams of the generating superposition. Let us suppose that we want the same ideal function as before. The figures 17 to 21 show the improved localized stationary wave field that satisfies this situation: but now we have used 181 annular slits (i.e., 181 Bessel beams) and a lens with focal length of 10.5cm and aperture of 1.5mm (new source size). We can observe in Fig.20 a much smaller residual intensity. In Fig.21 the transverse behavior of this localized stationary wave field is shown, in the plane $z = z_f$

Increasing the spatial resolution: Situation (2)

The spatial resolution of the localized stationary wave field (FW) can be increased. Let us suppose that we want the same configuration of situation (1), however with a width of 0.15mm, ten times smaller than before. The Figures 22 to 26 show the localized stationary wave field for this situation. We still have 181 annular slits and a lens with focal length of 10.5cm and aperture of 1.5mm (*source size*).

Microwave case: Situation (3)

Let us suppose that we want a (free space) microwave field ($\lambda = 1\text{cm}$) in the interval $0 \leq z \leq 2\text{ m}$ with a spatial resolution of 8 cm, localized around $z=z_f=1\text{m}$. We can construct such a field by using a parabolic function centered at z_f with a width of 8 cm. Figures 27 to 30 show such a stationary wave field, by superposition of 29 Bessel beams, corresponding to what we call situation (3). Figure 27 shows the 2D plot [the line indicated by $F(z)$ is the desired field, while the line indicated by FW is the localized stationary wave field actually obtained] Fig.28 shows the 3D representation corresponding to fig.27, and Fig.29 is an orthogonal projection. In Fig.30 we recast Fig. 27 in decibel, to show the residual intensity in a more clear way. In this case the source can be manufactured by using discrete sources located in the plane $z = 0$ along a circular aperture of radius 0.7m, or by using again an array of annular slits. In the latter case, the radii of such annular slits must get values of decimeters, with a microwave lens having a focal length of 1m and aperture radius of 0.7m (source size).

We can use 29 annular slits, with a minimum radius of 24cm and a maximum radius of 56cm. Other configurations would be possible too.

ACOUSTICS

Acoustic is another field where the localized stationary wave fields FW theory can be applied. In some situations it can be desirable to concentrate a high intensity of acoustic field inside specific regions.

Situation (4)

Now let us suppose that we want an acoustic field with a frequency of 8 MHz in the interval $0 \leq z \leq 20\text{cm}$, with a spatial resolution of 5mm, localized around

$z = z_f = 10\text{cm}$. We consider this field created inside a biological tissue, where the sound velocity can be taken as $c = 1500\text{m/s}$, while we are not considering losses. One can construct such pattern by using a parabolic function centered at z_f with a width of 5mm.

In Figures 31 to 34 the localized stationary wave field FW corresponding to this pattern is shown. Figure 31 shows the 2D plot [again the line indicated by $F(z)$ is the desired field, and the line indicated by FW is the localized stationary wave field actually obtained]. Fig.31 shows the 3D representation of figure 31, and Fig.33 is an orthogonal projection. In Fig.34 we recast Fig.31 in decibel, to show the residual intensity in a more clear way.

In this case the source can be manufactured by using discrete sources (transducers) located in the plane $z = 0$ along a circular aperture of radius 6cm, or by using again an array of annular slits. In the latter case, the radii of such annular slits must get values of centimeters, with an acoustical lens having focal length of 1m and aperture radius of 6cm (source size).

We can use 51 annular slits, with a minimum radius of 3.3cm and a maximum radius of 8.7cm. Other configurations would be possible too.

CONSIDERATION OF THE USE OF THE METHOD WITH HIGHER ORDER BESSEL BEAMS FUNCTIONS

Considering the use of higher order Bessel beams, an advanced method is disclosed.

According to the experience made up to now by the inventors, it is considered not a limitation, but rather a convenience, skipping the use of Bessel beams of order greater than fifth. Therefore, 1st, 2nd, 3rd, and 4th order Bessel functions were used in attempts for concentrating energy along one or more rings (or on the surface of a cylinder) with center on the propagation axis and

orthogonal to such an axis. Actually, the Bessel functions of order greater than zero possess zero intensity on the axis and circular pattern of intensity around the axis. The result of the application of the proposed method is the production of a cylindrically distributed power with a predefined intensity. This allows to produce, for instance, confining fields to be used (as an example) for confining particles during their motion (without any need of having a surrounding or inner field generator). Such a type of confinement can act even on neutral particles or objects, due to the impulse transferred by the intense field. Figure 36 illustrates the cross-section of such a Stationary wave field.

It is also possible to use in conjunction two emitters: one using zero-order Bessel beams, and the other using higher order Bessel beams, so, for example, to shield the action of external fields on the inner one. This can be particularly useful in systems very sensitive to electromagnetic perturbations, such as plasma fields. The above-mentioned application of the method allows also designing a transducer, able to produce a field for confining a plasma, when the typical problem is to contrast the radiation pressure that moves ions, particles and molecules from the hotter to the colder regions. In this case the stationary wave field produced by superposing higher order Bessel beams should be at least shaped as a cylindrical surface.

CONSIDERATION OF THE VARIOUS METHODS AND DEVICES TO CONTROL PHASE AND AMPLITUDE OF THE SUPERPOSED BEAMS: EMBODIMENTS

I) According to the disclosed method, each of the emitting elements of the antenna is characterized by its Transfer function. As already mentioned, in the case of optical (annular, etc.) slits, each slit may be covered by a proper super-thin film, in order to control amplitude and phase of the emitted (Bessel, etc.) beam. The process for obtaining this thin film is sometimes complicated or costly, and it is here disclosed that an alternative simple, cheap solution consists in using a series of

lenses. In specific applications similar to the mentioned (optical) one, just one suitable lens can be added: Such a lens (equal to the first one, that was located in such a way that the antenna falls in its rear focal plane) has to be designed and placed just after the slits, thus producing the proper phase shifts and reducing to an easier problem the amplitude control of the generated beams. And more in general of its transfer function

From the description of the above cases, it has become clear that alternative setups can be provided for constructing a source capable of generating a localized stationary wave field of the kind according to the present invention. Let us also recall that other forms of generation can be used, for example by holographic elements, axicons, and by discretized antennas of the type discussed hereinafter.

Namely, according to an alternative embodiment of a source for generating a localized stationary wave field with the method of the present invention, a field behaviour corresponding to the superposition of Bessel beams (leading to the said stationary localized wave field) can be achieved by using a series of spot-like emitters, so to produce an effect similar to the one produced by axially symmetric emitters. In such a case, the spot-like emitters can be either ceramic ultrasound generating spots (in acoustics), or micro and nano dipoles, photonic spots, macro, micro and nano grids (in optics or microwaves, etc.), and other similar emitters.

The superposition effect is obtained by exciting each of the spot-like generators with an appropriate phase and intensity, in order to have a global superposition effect similar to the one produced by rings. The advantage of this composed transducer is the capability to be properly tuned, in case of a non-uniform medium, by using e.g. feedback system on echoed/transmitted signals.

The method and apparatus according to the present invention can be applied to (or can provide) many different *specific* treatment methods, and many *specific* devices or tools.

In a *first specification* of the present embodiment of the invention, an optical or laser cutting device is generated by the concentration of laser waves at one point, or in a series of points. The aim is to have a segment constructed by spots of high intensity field. Figure 37 illustrates a schematic example of such a laser cutting device. In figure 37 the reference number 1003 indicates a body to be submitted to the cutting action, while the external environment is indicated with 1004. A high energy laser emitter or a high energy ultrasound transducer 1010 is placed at an end of a rod-like handle 1007. The laser emitter or the ultrasound transducer is energized by means of a supply means 1008 which is guided to the emitter/transducer 1010 through the handle 1007. The emitter/transducer 1010 is supported at an end of the handle 1007 in such a way that the line of field projection indicated by the dotted line 1002 in fig. 37 is at least approximately oriented in the axial direction of the handle 1007. The emitter/transducer is enclosed on the side of the environment surrounding the object to be cut by a cup shaped head 1006. This cup-shaped head 1006 has a rounded edge at the zone opposite to the emitter/transducer, enabling a simpler sliding of the head on the surface of the object on which the cutting action is carried out. The triangular black dots indicate by the numeral 1009 indicates the cutting or separation line. In prior art, optical or laser cutting tools are known, also as surgical beams for example, but the present invention is able to produce a more intense field than by the known devices with the same energy input. Moreover the region interested by the field is very limited and sharply defined, and can be controlled with a very high precision. Due to the capacity of the localized stationary wave fields according to the present invention to concentrate the whole

energy inside a confined volume of predetermined dimension and shape, while reducing to a negligible level the energy spread outside the said volume. This is particularly important when considering a surgical cutting tool, or similar devices, since no disturbance or modification is produced in the tissues or material before and after the high-field region (where the cutting action has to be carried out).

II) A second preferred embodiment of the present invention is the generation of optical or electromagnetic tweezers, useful for microscopic manipulation such as DNA cutting or even single particle capturing. Actually, in previous art some tools of this type are known, but there is no skilled approaches -for instance- for confining a particle (even neutral, due to exchange of mechanical impulse with the photons of the stationary field) with the precision reachable by the use of the antennas, in particular transducers, designed according to the method of the present invention. The use of Bessel beams is well-known, but the generation of a proper superimposition of Bessel beams in order to create a *stationary* wave field (able for instance to exchange mechanical impulse with the particle) is one of the novel applications of the mentioned new type of tweezers.

III) A further preferred embodiment refers to optical micro-lithography. In previous art, Bessel beams are used in such a field to produce pattern for successive etchings, but there is a limit in controlling with precision the etching positioning. By using the present method, an antenna, i.e. a source (in particular, a transducer) can be determined in order to get a predefined precision, that is limited by the wave dimensions only, thus increasing dramatically the etching depth resolution, besides its transverse resolution.

IV) Still another preferred embodiment of the present invention is the generation of electromagnetic (or acoustic)

"balls", so to be able to transmit power from a location to another with minimum losses. This is further favoured by the property of each Bessel beam, constructing by interference the stationary "ball", of rebuilding its own shape after an obstacle. When the obstacle dimensions are smaller than the size of the lens (belonging to the antenna/transducer), each of the beams bypasses any obstacle on its route, recomposing finally the stationary field. One of the results is a reduced sensitivity to environmental perturbation. It must be recalled, at this point, also that, inside the 3D envelope (or envelopes) constituting the FW, there is a propagating carrier wave, i.e., a propagating plane wave given by

$$\exp[iQz - (\omega_0) t].$$

V) Still another preferred embodiment of the present invention is an apparatus for a new kind of "tele-communications". The method allows designing an antenna/transducer, able to create a stationary field envelope at a first space position only, which will not be detectable, of course, at a second, different position. If the position of the desired receiver is known with good approximation, it is possible to design the transducer in order to generate a positive superimposition of the composing Bessel beams in that specified region of space only.

VI) Still another preferred embodiment of the present invention is a new kind of flexible holography, i.e., the generation of a three-dimensional image through the accurate phase tuning of the Bessel (or other) superposed beams. To this purpose, an antenna, or transducer, is disclosed (using, e.g., MEMS, piezoelectric effects, thermal effects,...) able to modify the rings for example modifying the radii or even the thickness, in a coordinated way together with the phase of the composing Bessel (or other) beams coming from the multi-channel generator. In such a way, a three-dimensional image can be generated without the need of ordinary holographic technology. Moreover, such a three-dimensional image

could be moved around by such antenna/transducer, even changing its shape in time, resulting in a much better flexibility of the "holographic" arrangement

VII) Another preferred embodiment of the disclosed method is the design of a sound region, limited in space. This allows generating an area of sound not propagating outside it. A transducer is described, able to produce such an effect. The effect is useful for replacing earphones with an immaterial earphone by creating, "projecting" the sound from the special transducer. In this case as already disclosed in a more general case, a spatially confined and stationary envelope of an acoustic field can be generated by means of the method according to the present invention. While inside the envelope acoustic beams can generate the acoustic sounds

EMBODIMENTS IN THE SECTOR OF THERAPEUTIC OR DIAGNOSTIC TREATMENTS OR METHODS IN MEDICINE:

Particular attention is to be given to the use of the method according to the present invention in the field of *therapeutic or diagnostic* treatments or methods, and of the corresponding tools.

In the medical field, applications for cancer treatment, calculus destruction, thermal therapies have been investigated and analysed, in order also to describe advantages of the use of the present method compared with the existing ones. Moreover, technical considerations based on the use of the disclosed method permit the design of complete new therapies, and an improvement of existing ones.

The characteristics of the stationary field (FW), cited above, due to the present invention are principally, but not exclusively:

- Residual Intensity
- Spatial Resolution

- Minimum Distance from a source generating the localized field ("Frozen Waves")
- Source Size
- Penetration Depth of the Frozen Waves

For medical purposes, the method of the localized stationary wave fields, according to the present invention, would a priori yield more useful results for high frequency electromagnetic/optical or acoustics fields. In fact, with high frequencies, it is possible to deal with smaller sources and higher spatial resolution. We could think even about Gamma or X rays applications.

Practical examples of the use of the present invention in therapy and diagnostic and for providing new therapeutic and diagnostic devices are described in more detail in the following:

VIII) According to a first embodiment (for this new sector) of the use of localized stationary wave field due to the present invention in the sector of medicine, an apparatus able to destroy tumours is provided, which carries out its action on the tumoral mass by irradiating it with (intense) localized, stationary energy.

In the prior art, there are several transducers and methods for similar functions, but they are all affected by the negative characteristic of irradiating also the intermediate tissues located before and after the tumour, thus reducing drastically the time for each irradiation and elongating the therapeutic cycle, besides all the other known negative side effects. The use of electromagnetic waves is difficult since it is easy to concentrate high (localized, stationary) energy inside a small spot via microwaves, i.e., short wavelength (e.g., few millimetres) waves: But such waves hardly penetrate beyond the skin, so this technique and apparatus could be suitable only for superficial diseases.

By contrast, 300-500MHz, till about 1GHz, waves (endowed with wavelength of almost 1 m) are able to penetrate the human body. Concentrating these long waves into a limited region can be possible only by using antennas of a few meters diameters with a

focal length not less than some meters, confining their use in important therapeutic treatments, according to the literature of the area.. Anyway, the present invention allows concentrating enough such short or long electromagnetic waves, to use them for curing tumours.

According to an *alternative embodiment* the said device could be also used as image transducers and/or receivers capturing transmission or reflection beams, to detect and record the position of significant biological features such as tumors, with the possibility of avoiding the use of ionizing radiation or intense magnetic fields.

IX) Another preferred embodiment of the present invention in the medical field consists in an apparatus able to destroy tumours by using *ultrasounds*. Similar devices are well known in the area, using multiple patterns or a variable pattern to concentrate the ultrasound on a defined target, while trying to reduce the amount of residual dose on the surrounding tissues. In the disclosed embodiment, the transducer designed according to the abovementioned method allows to generate an extremely high concentration of ultrasound on the target, or rather inside a predetermined spatial-region (spot), and a really negligible effect on the material before or after or surrounding the target, to the superimposition of proper Bessel (or other) beams according to the present invention.

A multi-transducer generates a sound field by superimposition of acoustic Bessel (or other) beams, according to the method, thus producing a high power acoustic field inside a very limited volume, of the order, e.g., of one cubic millimetre or much less. This allows destroying tumour masses without damaging tissues before or after or surrounding the focusing area.

X) Another similar preferred embodiment of the disclosed method is a method and an apparatus for the destruction of calculus (e.g., kidney stones) by the mechanical action of stationary acoustic

waves in the calculus volume. This is an advantage compared to prior art, since in the prior art devices a similar action is performed, but the area of intense field is not defined precisely as in an apparatus using a localized stationary wave field according to the present invention, so that in the prior art devices the surrounding tissue is damaged.

XI) Another preferred embodiment of the disclosed method is the capability of performing needle-less injections of medicines and liquids, by using a highly concentrated sound or ultrasound field, with a predetermined shape. The "needle" can be actually generated in the form of an intense stationary field extending from above to below the patient skin (with a predetermined penetration depth also inside the patient body). A dose of medicine is laid on the skin and the field is alternatively switched on and off. This produces the passage of a small quantity of material from the dose through the skin. Repeating the cycle it is possible to introduce and disperse high quantity of medicines in the desired area/volume, in order to optimize adsorption and therapy

Figures 38a and 38b illustrates respectively a device for performing needle-less injections by applying the teachings according to the present invention. In the perspective view of figure 38a a portion of dermis 2002 and epidermis 2003 is shown. As reference to the dimensions of the needle-less device disclosed the pores structure 2001 is also illustrated. A first acoustic or mechanical field emitter 2006, such as for example an ultrasound transducer, is placed at the external surface of the dermis at the point at which injection has to be carried out. At this point or zone a drop 2004 of medicine compound is deposited. The first transducer 2006 generates a field having a stationary and spatially localized envelope with inner moving wave fronts which pushes the medicine or compound 2004 through the dermis and epidermis 2002, 2003. The stationary and spatially localized envelope of the field generated and extending through the dermis and epidermis 2004 is illustrated with dotted lines and is

indicated with the reference numeral 2005. A further secondary emitter, particularly an ultrasound transducer 2007 is provided. This emitter/transducer 2007 is of annular form and generates a cylindrical tubular, additional containment field 2008. The transversal intensity pattern of the said tubular additional containment field is illustrated in figure 38b. Such a kind of field having a stationary spatially confined envelope can be obtained according to the present invention by using superpositions of higher order waves, particularly of Bessel beams, than zero order waves or Bessel beams.

Referring to Figure 39 therein there is illustrated the case where inside a stationary envelope or sub-envelopes any kind of propagating wave can be generated and not only a plane wave: for example in such a way to generate a peak which is born on a first side of the envelope or sub-envelope and dies on the other side of the said envelope or sub envelope, while a second peak appears on the said first side. The dotted circles 3001 indicate a wavefront inside the stationary localized envelope which borders are indicated by the continuous lines 3003, 3004 and 3005. with numerals 3002 a particle, a drop or a cell in any kind of object is indicated which interacts with the wave front. The wave front is borne on the left side and dies on the right side of the envelope, namely respectively at 3003 and 3004, while it is transversally confined by the envelope borders 3005.

It has to be noticed that, although the present method has been described with reference to a superposition of Bessel beams, other kinds of beams can be used. Particularly suited beams are the ones having an high transverse confinement. This leads to a high transverse concentration of the energy. In particular, beams can be used whose crosssection is not circular but elliptical, or whose transverse energy distribution is represented by other functions having at least one high narrow peak (centered on the

propagation axis, or elsewhere: e.g., along a circumference surrounding the z-axis) decreasing to negligible amplitudes.

In the present description and in the claims the definition "Bessel beams" will be understood as comprising any kind of other beams suitable for carrying out the method according to the invention.

Deeper details of the theoretical scientific background of the present invention are disclosed in the following references which are part of the present description:

J.-Y.Lu and J.F.Greenleaf: "Experimental verification of nondiffracting X-waves", IEEE Trans. Ultrason. Ferroelectr. Freq. Control, vol.39 (1992) pp.441-446.

E.Recami: "On localized 'X-shaped' Superluminal solutions to Maxwell equations": Physica, vol.A252 (1998) pp.586-610.

M.Z.Rached, E.Recami, and H.E.Hernandez F.: "New localized Superluminal solutions to the wave equations with finite total energies and arbitrary frequencies", Europ. Phys. J., vol.D21 (2002) pp.217-228.

E.Recami, M.Z.Rached, K.Z.Nobrega, C.A.Dartora, and H.E.Hernandez F.: "On the localized superluminal solutions to the Maxwell equations" IEEE J. Sel. Top. Quantum Electronics, vol.9(1) (2003) pp.59-73.

M.Z.Rached, K.Z.Nobrega, H.E.Hernandez-F., and E.Recami: "Localized Superluminal solutions to the wave equation in (vacuum or) dispersive media, for arbitrary frequencies and with adjustable bandwidth", Opt. Commun., vol.226 (2003) pp.15-23.

M.Z.Rached, A.Shaarawi, and E.Recami: "Focused X-shaped pulses", in press in J. Opt. Soc. Am., vol.A21 (Aug.,2004).

CLAIMS

1. Method for producing a stationary **localized** wave field of **an a-priori predetermined** arbitrary shape comprising the following steps:

a) defining at least a volume being limited in the direction of the axis **z** of propagation of a beam, a so called longitudinal interval, of the type $0 \leq z \leq L$;

b) defining **a priori** within the said longitudinal interval an intensity pattern $|F(z)|^2$ describing the desired localized and stationary wave field **which function $F(z)$ is represented by means of a discrete Fourier Series or by a similar expansion in terms of** ~~be approximated by means of a~~ (trigonometric) orthogonal functions; ~~or in particular Fourier expansion;~~

c) providing a **discrete**, generic superposition of Bessel beams **or other highly transversally confined beams**;

d) calculating the maximum **allowed** number of ~~superimposed~~ Bessel beams **to be superposed**;

e) **calculating** the amplitudes, and the phase velocities of ~~each Bessel beam of the superposition, as well as~~ **and** the transverse and longitudinal wavenumbers of each Bessel beam of the superposition, needed to obtain the predefined STATIONARY intensity pattern (within the predefined longitudinal interval);

f) **recognizing and controlling the effect of each of the said parameters under point e) for controlling the longitudinal shape of the stationary localized wave field**;

2. Method according to claim 1, in which the Bessel beams or the beams having a high transverse confinement have the same frequency.

3. Method according to claim 1, in which the Bessel beams or the beams having a high transverse confinement have different frequencies.

4. Method according to claim 1, in which the Bessel beams or the beams having a high transverse confinement have a certain bandwidth.

5. Method according to one or more of the preceding claims 1 to 4, in which the Bessel beams or the beams having a high transverse confinement are pulsed.

6. Method according to one or more of the preceding claims, wherein the Fourier expansion defining the intensity pattern within the said (at least one) confined space-region is a trigonometric expansion

7. Method according to claim 6, wherein the Fourier expansion defining the intensity pattern within the said at least one longitudinal interval is a Fourier-type series.

8. Method according to one or more of the preceding claims, wherein the generic superposition of Bessel or other beams is given e.g. by the following function:

$$\Psi(\rho, z, t) = e^{-i\omega_0 t} \sum_{n=-N}^N A_n J_0(k_{\rho n} \rho) e^{i\beta_n z} \quad (5)$$

where n are integer numbers, A_n are constant coefficient, and $\beta_n, k_{\rho n}$ are the longitudinal and transverse wavenumbers, while ω_0 is the frequency and ρ, z are cylindrical coordinate and t is the time, while in the said equation (5), for each n the parameters $(\omega_0, k_{\rho n}, \beta_n)$ must satisfy the condition

$$k_{\rho}^2 = \frac{\omega^2}{c^2} - \beta^2 \geq 0 \quad (3)$$

and the intensity pattern in correspondence of a predefined delimited longitudinal interval, defined as $0 \leq z \leq L$, is given e.g. by the following Fourier-type series:

$$F(z) = \sum_{m=-\infty}^{\infty} B_m e^{i \frac{2\pi}{L} m z} \quad (7)$$

with

$$B_m = \frac{1}{L} \int_0^L F(z) e^{-i \frac{2\pi}{L} m z} dz . \quad (8)$$

The specific superposition of Bessel (or other) beams needed for obtaining at least approximately the defined intensity pattern within the chosen space-region is defined e.g. by the following function:

$$\Psi(\rho = 0, z, t) = e^{-i\omega_0 t} e^{iQz} \sum_{n=-N}^N A_n e^{i \frac{2\pi}{L} n z} \quad (11)$$

with the amplitudes A_n given by

$$A_n = \frac{1}{L} \int_0^L F(z) e^{-i \frac{2\pi}{L} n z} dz \quad (12)$$

the maximum number N of superimposed Bessel (or other) beams being defined by

$$0 \leq Q \pm \frac{2\pi}{L} N \leq \frac{\omega_0}{c} \quad (10)$$

while the longitudinal wavenumbers are defined by

$$\beta_n = Q + \frac{2\pi}{L} n \quad (9)$$

wherein Q is an empiric parameter which can be chosen provided that:

$0 < Q < (\omega_0)/c$; and L is the length of the considered longitudinal interval.

9. Method according to claim 8, wherein the cylindrical coordinate ρ is different from zero, and , such that the superposition of Bessel beams for obtaining the desired intensity pattern in correspondence with the considered longitudinal interval, is given by

$$\Psi(\rho, z, t) = e^{-i\omega_0 t} e^{iQz} \sum_{n=-N}^N A_n J_0(k_{\rho n} \rho) e^{i \frac{2\pi}{L} n z} \quad (13)$$

with

$$k_{\rho n}^2 = \omega_0^2 - \left(Q + \frac{2\pi n}{L} \right)^2 \quad (14)$$

10. Method, according to one or more of the preceding claims, wherein the function $F(z)$ describing the intensity pattern within a confined volume (or more confined volumetric regions, corresponding each to a predetermined longitudinal interval in the direction of propagation of the beam) is one step function or a combination of step functions.

11. Method according to claim 10, characterized in that the function $F(z)$ is a function piecewise continuous in the interval $0 \leq z \leq L$.

12. Method, according to one or more of the preceding claims, characterized in that the Bessel beams are mechanical wave beams including seismic and geophysical waves, or similar

13. Method, according to claim 12, characterized in that the mechanical wave beams are acoustic waves;

14. Method, according to one or more of the preceding claims 1 to 11, characterized in that the Bessel beams are electromagnetic wave beams.

15. Method, according to one or more of the preceding claims, characterised in that the stationary field is an electric field

16. Method, according to one or more of the preceding claims, characterised in that the stationary field is a magnetic

17. Method, according to one or more of the preceding claims, characterised in that the Bessel beams are gravitational wave beams.

18. Method according to one or more of the preceding claims, characterised in that the Bessel beams are wave beams representing fundamental particles.

19. Method, according to one or more of the preceding claims, characterized in that more than one confined spatial volume are provided wherein a stationary wave field is present; on defining more than one longitudinal intervals and providing a function $F(z)$ for describing the wave field intensity pattern corresponding to more than one longitudinal intervals, the said longitudinal intervals being at the desired distance one from the other, and by carrying out the steps of one or more of the preceding claims by applying the said function $F(z)$.

20. Method, according to one or more of the preceding claims, characterized in that the Bessel beams of the superposition of Bessel beams are zero order Bessel beams.

21. Method, according to one or more of the preceding claims, characterized in that at least a part of the superposition of Bessel beams comprises also higher-order Bessel beams than zero order Bessel beams.

22. Method, according to one or more of the preceding claims, characterized in that all or some of the Bessel beams of the superposition of Bessel beams are Bessel beams of higher order than zero order, in particular of second, third or fourth order

23. Method for producing a source for generating a *stationary* wave field of arbitrary shape comprising the following steps:

providing one source for a single Bessel beam of frequency ω_0 ;

generating an array of more than one of the said sources of Bessel beams;

configuring each source of the said array of Bessel beam sources in order to get the desired, prefixed amplitude, phase, and the longitudinal coefficient or wavenumber of the emitted Bessel beams, entering the superposition of Bessel beams defined according to the method steps of claims 1 to 22.

24. Method according to claim 23, in which only the longitudinal wavenumber is determined, while the transverse wavenumber is calculated with equation, Eq.(3).

25. Method, according to claim 23 or 24, characterized by the following steps:

a) defining at least one space-region being limited in the direction of the axis of propagation of the beam corresponding to one longitudinal interval of the type $0 \leq z \leq L$;

b) defining an intensity pattern in correspondence with the said at least one longitudinal interval by a function $F(z)$, which is approximated by means of a Fourier or a trigonometric expansion ;

c) providing a generic superposition of Bessel beams or other beams having an high transverse confinement;

d) calculating the maximum number of superimposed Bessel beams, the amplitude and phase of each Bessel beam of the superposition, as well as the transverse and longitudinal wavenumbers of each Bessel beam of the superposition, needed to

obtain the defined intensity pattern within the defined longitudinal interval by the arbitrary function $F(z)$, which describes the longitudinal intensity pattern within the said longitudinal interval and is approximated by means of the said Fourier or trigonometric expansion;

e) providing a number of Bessel beam sources or of sources of other beams having an high transverse confinement corresponding to the number of Bessel beams or of other beams of the superposition of Bessel beams or other beams needed for generating the desired intensity pattern (inside $0 \leq z \leq L$), which can be axially and transversally delimited by one or more "envelopes";

automatically obtaining a transversal localization of the stationary fields by means of above superposition of for instance zero order Bessel beams.

f) each one of the said Bessel beam or other beam sources generating a specific Bessel beam or other beam of the said superposition of Bessel beams or other beams;

g) arranging the said Bessel beam sources or other beam sources in an array of Bessel beam or other beam sources with univocally defined spatial relations (for instance, in the particular case of annular sources, with univocally determined radii and transfer functions.);

h) configuring each of the Bessel beam sources in order to generate the corresponding Bessel beam of the superposition of Bessel beams with the specific amplitude, phase (or relative phases), longitudinal and transverse wavenumbers according to one or more of the steps in claims 1 to 22.

26 Method according to claim 25, in which the function $F(z)$ is chosen, within the interval $0 \leq z \leq L$, so to be concentrated inside small regions $L_1 < z < L_2$ so to be constituted by one or more *STATIONARY sub-envelopes*

27. Method according to claim 25 or 26, in which the Bessel beams or the beams having a high transverse confinement have the same frequency.

28. Method according to claim 25 or 26, in which the Bessel beams or the beams having a high transverse confinement have different frequencies.

29. Method according to claim 25 or 26, in which the Bessel beams or the beams having a high transverse confinement have a certain bandwidth.

30. Method according to claim 25 or 26, in which the Bessel beams or the beams having a high transverse confinement are pulsed.

31. Method, according to one or more of the preceding claims 23 to 24 characterized in that an initial ordinary generator creates a suitable mechanical or electromagnetic beam and directs such an "entering beam" against an interference device, being formed for instance by an array of concentric annular slits, each annular slit in combination with a lens or a super-thin film being the source of a corresponding Bessel beam of a superposition of the Bessel beams, the spatial relation between (for instance) the annular slits, their width, and even more their RADII and Transfer Functions -which can be controlled by this films-defining amplitude, phase, transverse and longitudinal wavenumbers of the Bessel beam generated by each one of the slits.

32. Method according to one or more of the preceding claims 23 to 31 characterized in that the generation process of Bessel or other beams is performed by holographic elements, in optics and millimetre waves, such as computer-generated-holography (CGH) or spatial-light-modulator (SLM) devices or the like, or by axicons plus lenses, or by arrays of transducers with and without the need of a lens, since the final field given by Eq.13 is directly

generated on the plane $z=0$ by suitable excitation of the transducers).

33. Method, according to claim 31, characterized in that (for instance) the radius of each annular slit of the array of coaxial annular slits for each corresponding Bessel beam of the superposition of Bessel beams is determined, by choosing the values of Q , ω_0 , L and the lens focal length f according to equation (25), the said radius providing the generated Bessel beam with the correct longitudinal and transverse wavenumbers given by Eqs.9 and 14 in Claims 4 and 5, respectively, while the transfer Function of each annular slit, instead, will provide the corresponding Bessel beam with the correct amplitude and phase given by Eq.(12) in Claim 4. wavenumber

34. Method, according to one or more of the preceding claims 22 to 33, characterized in that the Transfer Function of each one of the considered (for instance) annular slits is theoretically and experimentally defined, so that it determines relative phase and amplitude of the Bessel beam generated by the said annular slit, the radius of such an annular slit determining the longitudinal and transverse wavenumbers of the Bessel beam generated by it; these wavenumbers being obtained with the method according to one or more of the preceding claims 1 to 22.

35 Method according to one or more of the preceding claims 22 to 34, characterized in that the slit width δa *Contributes to tuning* the value of the amplitude of the Bessel beam generated by it.

36. Method, according to one or more of the preceding claims 33 to 35, characterized in that, for the Bessel beam generated by each (n -th) annular slit, an apparatus characteristic coefficient Λ_n is defined, which is determined either empirically or by means

of calculation, according to the invention: the said apparatus characteristic coefficient being inversely related to the transfer function

37. Method, according to one or more of the preceding claims 22 to 36, characterized in that the source beam is a laser beam or a microwave beam or an acoustic beam or a gamma beam or an X-ray beam, RF beam or Lw or MW beam, IR or NIR beam or similar.

38. Method, according to one or more of the preceding claims 22 to 37, characterized in that it provides sources generating electromagnetic Bessel beams; comprising:

an initial ordinary generator of an electromagnetic beam, and (for instance) an array of a certain number n of annular concentric slits interfering with the said electromagnetic beam followed by an electromagnetic lens;

the lens having focal length f and radius R .

The total number n of annular slits being equal to $2N+1$, where N is the maximum value of n given by Eq.(10) in Claim 4.;

The generic, n -th annular slits having a radius a_n depending on its index n and on Q , L , and f ; the integer n being comprised in the range defined by the relation

$$-N \leq n \leq N ,$$

the wave field or intensity pattern generated (e.g.) by the array of annular slits being defined by the following superposition of Bessel beams:

$$\Psi(\rho, z, t) = e^{-i\omega_0 t} \sum_{n=-N}^N \Lambda_n T_n J_0(k_{\rho n} \rho) e^{i\beta_n z} \quad (20)$$

where T_n are the *transfer functions* of each annular slit regulating amplitude and phase of the emitted Bessel beams, and regarded as constants for each slit, while Λ_n are constants depending on the characteristics of the apparatus;

the transverse and longitudinal wavenumbers being given by

$$k_{\rho n} = \frac{\omega_0 a_n}{c f} \quad (22)$$

and

$$\beta_n^2 = \frac{\omega_0^2}{c^2} - k_{\rho}^2 \quad (23)$$

and the characteristic radius of the n -th annular source with a small width, enough for causing a noticeable diffraction being given by the equation

$$a_n = f \sqrt{1 - \frac{c^2}{\omega_0^2} \left(Q + \frac{2\pi}{L} n \right)^2} \quad (25)$$

the transfer function of each annular slit, determining the correct amplitude and phase of each n -th Bessel beam emitted by the corresponding n -th slit, being calculated by means of the following equation:

$$T_n = \frac{A_n}{\Lambda_n} = \frac{1}{L \Lambda_n} \int_0^L F(z) e^{-i \frac{2\pi}{L} n z} dz \quad (26)$$

where A_n are coefficients defined by

$$A_n = \frac{1}{L} \int_0^L F(z) e^{-i \frac{2\pi}{L} n z} dz \quad (12)$$

$F(z)$ being the function which describes the desired wave field or intensity patten within the desired localized space-region and corresponding to the prefixed longitudinal interval,

Λ_n being the determined apparatus coefficients; that means that each Λ_n is the *complex* multiplicative constant that yields amplitude and phase of the Bessel beam generated by the n -th annular slit *with transfer function equal to 1*.

39. Method, according to claim 38, wherein the determined apparatus coefficients are approximately defined when δa is almost equal to zero as

$$\Lambda_n = \frac{a_n \omega_0 \exp\left[\frac{i\omega_0 a_n^2}{2cf}\right]}{2\pi c f i} \quad (21)$$

where a_n is the radius of the n -th annular slit,
 ω_0 is the frequency of the electromagnetic beam,
 f is the focal length of the lens
 c is the light speed in vacuum, or in the possible medium.

40. Method, according to one or more of the preceding claims 22 to 39, characterized in that a lens is provided behind the array of annular slits relatively to the beam propagation direction.

41. Method, according to claim 22, characterized by providing an array of spot-like (for instance) annular transducers or slits, each of the said spot-like discretized slits or transducers being excited with a certain phase and intensity in order to generate a global superposition effect, similar to the one generated by an array of continuous coaxial slits; the form of the excitation, being given by the function superposition Eq. (13) in Claim 5 when putting in it $z=0$.

42. Method, according to claim 41, characterized in that the spot-like emitters are, e.g., ceramic or semiconductor-based ultrasound generating spots; microwaves antennas; micro or nano dipoles; photonic spots; macro, micro or nano grids; or the like.

43. A source for producing a stationary wave field of arbitrary shape being produced with the method according to one or more of the preceding claims 1 to 42 characterized in that it comprises an array of Bessel or other beam sources having an high transverse confinement, each of which sources is devoted to the generation of a Bessel beam or other beam having different parameters of amplitude, phase, and longitudinal wavenumber and

transversal wavenumber; means for driving each source to generate a Bessel beam having frequency identical or different to the one of the other Bessel beams generated by the other sources of the array.

44. A source, according to claim 43, characterized in that the array of Bessel beam sources are in the form (for instance) of a set of annular concentric or coaxial sources, each annular source generating a Bessel beam with a defined amplitude, phase, longitudinal and transverse wavenumbers.

45. A source, according to claim 43 or 44, characterized in that it is a source of a superposition of Bessel beams or other beams having an high transverse confinement for generating a *stationary and confined* electromagnetic wave field, the source comprising an initial generator of an electromagnetic beam, the beam being directed against an annular array of concentric annular slits having $2N+1$ annular slits and each slit generating out of the impinging electromagnetic beam a Bessel or other beam endowed, e.g., with the same frequency or with the different frequency as the other Bessel beams or other beams, but possessing characteristic amplitude and phase, and characteristic longitudinal and transverse wavenumbers; a lens on the output side of the array of annular concentric slits, so that the array is located at the focus of the lens, the said slits having a radius defined for each n -th annular slit by the following expression:

$$a_n = f \sqrt{1 - \frac{c^2}{\omega_0^2} \left(Q + \frac{2\pi}{L} n \right)^2} \quad (25)$$

where L is the extension of the longitudinal space interval corresponding to the confined space-region in which the wave field

is created, f is the focal length of the lens, and Q is a positive constant contained in the interval $0 < Q < \omega_0/c$.

The radial width of each annular slit having to obey only the condition $\delta a \ll \lambda_f / R$.

46. A source, according to one or more of the preceding claims 43 to 45, characterized in that it is a source for a superposition of Bessel beams having equal frequency.

47. A source, according to claim 43 to 45, characterized in that it is a source for acoustic, electromagnetic, gamma ray or X-ray or ultrasound Bessel beams.

48. A source, according to one or more of the preceding claims, comprising at least one initial beam generator, at least one diffraction pattern against which the initial beam is directed, the diffraction pattern being formed for instance by an array of coaxial annular slits, the Transfer Function and the radius of each annular slit being correlated with amplitude, phase and wavenumbers (longitudinal and transverse), respectively, wavenumber wavenumber of the corresponding Bessel beams, the said correlation being determined in such a way as to generate a superposition of Bessel beams having the same frequency or different frequencies.

49. A source, according to one or more of the preceding claims, characterized in that an additional lens (with the same focus f) is provided immediately after the array of coaxial annular slits, the said lens making simpler the construction of the Transfer Function of the annular slits.

50. A source, according to one or more of the preceding claims 22 to 49, characterized in that it is formed by an array of spot-like emitters, while means for driving or exciting

selectively the said spot-like emitter are provided so that they excite those spot-like emitters with a predetermined phase and intensity given by Eq.(13) in Claim 5, to obtain a global superposition effect, similar but able to produce much more powerful stationary wave fields to the one of the superposition of Bessel beams defined with the method according one or more of the preceding claims 1 to 42.

51. A method according to one or more of the preceding claims 1 to 42, characterized in that Bessel beams or other beam having an high transverse confinement of different order are provided in the superposition of Bessel beams or other beams having an high transverse confinement, the said beams being generated with the method according to one or more of the preceding claims 1 to 42, while the transfer functions of the annular slits act also as an angular modulator.

52. A source, according to claim 50, characterized in that the spot-like emitters are ceramic or semiconductor-based ultrasound generating spot, micro or nano dipoles, photonic spots, macro, micro or nano grids, or the like

53. Method, according to one or more of the preceding claims, characterized in that it is a method for carrying out mechanical actions (e.g., micro-actions) on solid or liquid particles and/or on molecules or atoms or elementary particles, by providing a stationary mechanical or electromagnetic wave-field within one or more confined space-regions having limited longitudinal and transverse extension according to the method of one or more of the preceding claims 1 to 42, thereby exerting a mechanical confinement of the particle trapped within the spatially confined stationary wave field: the said confinement taking place via linear-momentum and/or angular-momentum transfers from the field to the trapped particle.

54 Method according to one or more of the preceding claims, characterized in that the shape of the stationary wave field can be tailored in such a way to present a deep potential well in which a charged particle can be trapped, confining it in a precise and "deep" way, at the desired position.

55. The method, according to claim 53, characterized in that it is a method for transferring and/or sorting particles, in solid and/or liquid and/or gaseous form, from a location to another location, by providing a spatially confined wave-field extending from the starting location of the object to be transferred to the target location to which the object has to be transferred and then providing an alternative on/off switching of the stationary wave field.

56. Method, according to claim 53, characterized in that it is a method for needle-less injection of substances inside a body.

57. Method, according to claim 53, characterized in that it is a method for carrying out injections of substances in biologic tissues.

58. Method, according to claim 53, characterized in that it is a method for mechanically affecting or demaging particles localized within a space-region, the said method comprising the steps of

defining volume having a predetermined extension corresponding to a predetermined longitudinal interval along the beam propagation direction, and a predetermined radial extension: The said longitudinal interval and the said radial extension of that space-region coinciding with at least a part of the particle or object to be mechanically affected, or completely containing the said particle;

generating a stationary wave-field, according to the method of one or more of the preceding claims 1 to 42, only inside the said volume having frequency and intensity in order to affect or damage or break up the said particle or object, or at least the part thereof coinciding with the said space-region.

59. Method, according to claim 58, characterized in that the wave field is an acoustic wave field, particularly an ultrasound wave field.

60. Method, according to claim 53, characterized in that it is a method for generating tubular confinement or guiding walls, in which a stationary wave field is generated as a superposition of Bessel beams of the same frequency or different frequencies and of the first or higher order than zero order or combinations thereof, the stationary wave field being generated according to the method of one or more of the preceding claims 1 to 42.

61. Method, according to one or more of the preceding claims, characterized in that it is a method for generating electromagnetic envelopes for confining plasma and/or trapping electric or magnetic fields, and providing the steps of generating a tubular stationary wave field by superimposing Bessel beams of the same frequency or of different frequencies and of first or higher order according to the method of one or more of the preceding claims 1 to 42.

62. Method, according to one or more of the preceding claims, characterized in that it is a method for "transferring" energy, comprising the steps of generating electromagnetic and/or acoustic pellets. /

63. Method, according to one or more of the preceding claims, characterized in that it is a method for exercising a cutting

and/or damaging and/or lithographic action on a body, by means of a stationary action on a body, by means of a stationary wave field for example within the optical frequency domain according to the method of one or more of the preceding claims 1 to 42.

64. Method, according to claim 63, characterized in that it is a method for *cutting* by means of an optical blade constituted by a stationary wave-field for example an optical wave field within a suitably shaped confined volume.

65. Method, according to claim 63, characterized in that it is a method for carrying out etching in *microlithography* processing, by providing a tool consisting in a stationary wave-field for example an optical wave-field confined within a suitably shaped volume forming the etching head.

66. Method, according to one or more of the preceding claims, characterized in that it is a method for affecting, damaging or breaking up the objects placed inside a certain space-region, by means of a stationary wave field confined within a volume, the electromagnetic stationary wave field being determined according to the method of one or more of the preceding claims 1 to 42, and the confined volume corresponding to a longitudinal interval along the beam propagation direction and to a radial dimension, and touching at least part of the surface of the object to be affected or damaged or broken up and/or comprising at least part of the object to be affected or damaged or broken up..

67. Method, according to claim 66, characterized in that is a method for damaging tumour cells or destroying tumour masses and/or liquefying and/or eroding vascular plaques, either fatty or calcified, which are present in carotid artery and/or coronary artery and/or other vascular compartments either venous or arterial. .

68. Method, according to one or more of the preceding claims, characterized in that it is a method for generating an optical and/or acoustic stationary wave-field within a delimited volume, the said fields being generated according to one or more of the preceding claims 1 to 42, and the said trapped acoustic waves and/or optical waves forming visual or acoustic "messages"

69. Method, according to claim 68, characterized in that it is a method for generating holographic-type 3D images by exploiting the phase tuning of the superposed Bessel beams or of other beams having an high transverse confinement, generating the stationary field via suitable interference among the Bessel beams or the other highly confined beams so to get the predetermined shape of the light intensity patterns.

70. Method, according to claim 68, characterized in that it is method for generating sound effects in a limited region of space.

71. Method, according to one or more of the preceding claims, characterized in that it is a method for generating images of an object within an enclosure or embedded into another object; the method comprises the step of concentrating electromagnetic waves within at least part of the region occupied by the object to be imaged or detected.

72. A needle-less injection device characterized in that it comprises a source for an acoustic stationary wave field confined within a predetermined region of space, extending partially outside the target location, where a substance has to be injected, and a starting location where the substance is initially located, the stationary acoustic wave field being generated by a source according to one or more of the preceding claims and following the

method illustrated in one or more of the preceding claims, 1 to 42 means being provided for alternatively switching on and off the said source.

73. A device for cutting, characterized in that it comprises a source for generating a stationary wave field at one or more predetermined spots in space, the said source being made according to one or more of the preceding claims, and the stationary wave field being generated according to the method of one or more of the preceding claims 1 to 42.

74. Electromagnetic or optical *tweezers* and/or *acoustic tweezers*, characterized in that such device comprises a source for generating a stationary wave field at one or more predetermined spots in space, the said source being made according to one or more of the preceding claims and the stationary wave field being generated according to the method of one or more of the preceding claims.

75. A microlithography tool, characterized in that it comprises a source for generating a stationary wave field at one or more predetermined spots in space, the said source being made according to one or more of the preceding claims and the stationary wave-field being generated according to the method of one or more of the preceding claims; the source being driven in such a way as to generate stationary wave-fields within confined space-regions corresponding in shape to the desired patterns to be etched.

76. A device for transferring power from the source into a certain space-region, characterized in that it comprises a source for generating a stationary wave-field, the said source being made according to one or more of the preceding claims, and the stationary wave-field being generated according to the method of

one or more of the preceding claims, and in such a way as to generate electromagnetic or acoustic wave-fields confined inside envelopes endowed with the form of pellets, or the like, the plane wave propagating inside the stationary and spatially confined envelope or sub-envelopes.

77. Method according to claim 76, characterized in that inside the stationary envelope or sub-envelopes any kind of propagating wave can be generated and not only a plane wave: for example in such a way to generate a peak which is born on a first side of the envelop or sub-envelope and dies on the other side of the said envelope or sub envelope, while a second peak appears on the said first side.

78. A tool for treating tumours, characterized in that it comprises a source for generating a stationary wave field inside at least one (or more) predetermined limited space-regions, the said source being made according to one or more of the preceding claims, and the stationary (e.g., intense) wave-field being generated according to the method of one or more of the preceding claims, the said space region or regions coinciding with at least part (e.g., a very tiny part) of the tumour mass only, or enclosing at least part of, or the entire tumour mass, only.

79. A device according to claim 78, characterized in that electromagnetic waves are chosen preferentially in the frequency range of 1MHz to 100GHz

80 A device according to claim 79, characterized in tha the frequencies are expressed in nterms of harmonics of second, third and greater order..

81. A device according to claims 78 or 79 or 80, characterized in that it is a tumour imaging and/or localization and/or identification apparatus.

82. A device for treating tumours and/or for destroying calculosis by ultrasonic waves, comprising a source for generating a stationary wave-field inside at least one or more predetermined limited space-region, the said source being made according to one or more of the preceding claims, and the stationary wave field being generated according to the method of one or more of the preceding claims, and the said space region or regions coinciding with at least part of the tumour mass only, or enclosing at least part of, or the entire tumour mass, only; the wave-field being an acoustic wave field in the ultrasound frequency range.

83 A "telecommunication" device from the source to to limited space-region only where the limited space-region can comprise multiple spots, comprising a source for generating a stationary wave field inside one or more predetermined limited space regions, the said source being made according to one or more of the preceding claims, and the stationary wave field being generated according to the method of one or more of the preceding claims.

84. A device for generating holographic type 3D images inside a delimited space-region, comprising a source for generating a stationary wave field inside one or more predetermined limited space-regions, the said source being made according to one or more of the preceding claims, and the stationary wave field being generated according to the method of one or more of the preceding claims; and comprising means for phase modulating the Bessel beams of the superposition of Bessel beams needed for generating light intensity patterns in that delimited volume, the method providing

the steps of changing in time the position in space and the shape and image design of the holographic type 3d image.

85. A headphone, characterized in that it comprises a source for generating a stationary wave field inside one or more predetermined limited space-regions, the said source being made according to one or more of the preceding claims, and the stationary wave field being generated according to the method of one or more of the preceding claims 1 to 42.

86 A method according to claim 66, characterized in that it is a method for modifying biological tissue or cells via exposure to electromagnetic or mechanical waves as to obtain regenerative action and/or smoothing action and/or facilitating lipid-content reduction and/or water-content reduction as to exert cosmetic actions on biologic tissues and/or cells.

87 A method according to one or more of the preceding claims characterized in that other eigenfunctions of the transverse laplacian operator are used *in stead of* Bessel beams provided the said eigenfunctions yield a constant value (the same for all of them) along the z-axis.

88 A method according to one or more of the preceding claims characterized in that it comprises the steps of
generating a spatially localized wave field inside a body to be examined, particularly a biological body;
the said stationary wave field being a stationary and spatially localized envelope or a certain number of sub-envelopes within which wave are confined;
limiting the dimensions of the stationary and spatially localized envelope or envelopes to a dimension corresponding to the dimensions of a predefined part of the said body, such as an anatomical region and/or a tissue kind and/or an organ;

exciting by the waves inside the said stationary and spatially localized envelope or subenvelopes at the limited region the body to the generation of signals or to reflection or to transmission, detecting the said signals and/or the reflected and/or the transmitted waves and determining the modification on the said waves inside the stationary and spatially localized envelope or sub-envelopes occurred during reflection and/or transmission and/or analyzing the emitted waves due to excitation.

89 A method according to one or more of the preceding claims characterized in that it comprises the steps of

a) generating a spatially localized wave field at a first distance (SDD) from the source;

b) Positioning a body to be examined, particularly a biological body at a second distance (SID) less than the first distance (SDD);

c) Measuring the properties of the localized wave field at the first distance (SDD) in absence of the body; the properties being defined as the localized stationary wave longitudinal and/or transverse dimension and/or the localized stationary wave peak and/or average intensity and/or the localized stationary wave intensity standard deviation and/or the ratio between the localized stationary wave peak/average/median intensity and the intensity of the stationary wave field at predefined values of the intensity (for example -10dB, -20dB, -30dB,...)

d) Measuring the properties of the localized wave field at the first distance (SDD) in presence of the body;

e) relating the changes in the measured properties between step d) and c) to the body composition and/or morphology and/or functions and/or metabolism.

90 Method according to claim 89 characterized in that the source emits along a line and/or a fan angle and/or a cone angle.

91 Method according to claim 89 or 90 characterized in that the source generates a plurality of spatially localized wave fields.

92 Method according to claim 89 or 91 characterized in that the measured properties are coded in a numeric format and are arranged so as to form an image.

93 Method according to claim 89 to 92 characterized in that the different measurements of the properties of the localized wave field are taken at different angular positions of the body with respect to an axis ortogonal to the direction of propagation.

94 Method according to claim 93 characterized in that the measurements are used for a tomographic image reconstruction of the body.

95. Method according to one or more of the preceding claims characterized in that a stationary wave field is generated, the said stationary wave field being switched on/of with a frequency which can be identical or different form the wavelength of the wave field and/or with a non periodic time sequence.

96. Method according to one or more of the preceding claims in which a stationary wave field is generated the said stationary wave field being used as a scanning tool for generating imaging information of part of a target body the said information deriving from signals emitted or reflected from the body in response to the stationary wave field or from changes induced on the wavefield by transmission effects exercised by the body on the stationary wave field.

97. Method according to claim 96, characterized in that it is a tomografic imaging method.

98. A methdo according to one or more of the preceding claims, characterised in that **at least a partial control of the transversal shape of the stationary wave field is carried out by superposing high order Bessel beams.**

ABSTRACT

Method for producing a stationary wave field of arbitrary shape comprising the steps of defining at least one volume being limited in the direction of the axis of propagation of a beam, a so called longitudinal interval, of the type $0 \leq z \leq L$; defining an intensity pattern within the said region $0 \leq z \leq L$ by a function $F(z)$, describing the said localized and stationary intensity pattern, which is approximated by means of a Fourier expansion or by a similar expansion in terms of (trigonometric) orthogonal functions; providing a generic superposition of Bessel or other beams highly transversally confined; calculating the maximum number of superimposed Bessel beams or similar beams, the amplitudes, the phase velocities and the relative phases of each Bessel beam or similar beams of the superposition, and the transverse and longitudinal wavenumbers of each Bessel beam or similar beams of the superposition, needed to obtain the defined intensity pattern within the defined longitudinal and transverse interval (i.e., confined space-region) from a function $F(z)$, which describes the intensity pattern within the said at least one longitudinal interval and is approximated by means of the said Fourier or trigonometric expansion; the said superposition, more precisely generating, waves confined within one or more stationary envelope or sub-envelopes whose size defines the said localized space-region or regions and such envelope or sub-envelopes (when more than one) being created with a predetermined distance between them, while inside the stationary envelope or each of the stationary sub-envelopes and only inside the said envelope or the said sub-envelopes a wave with predetermined characteristics will be moving.

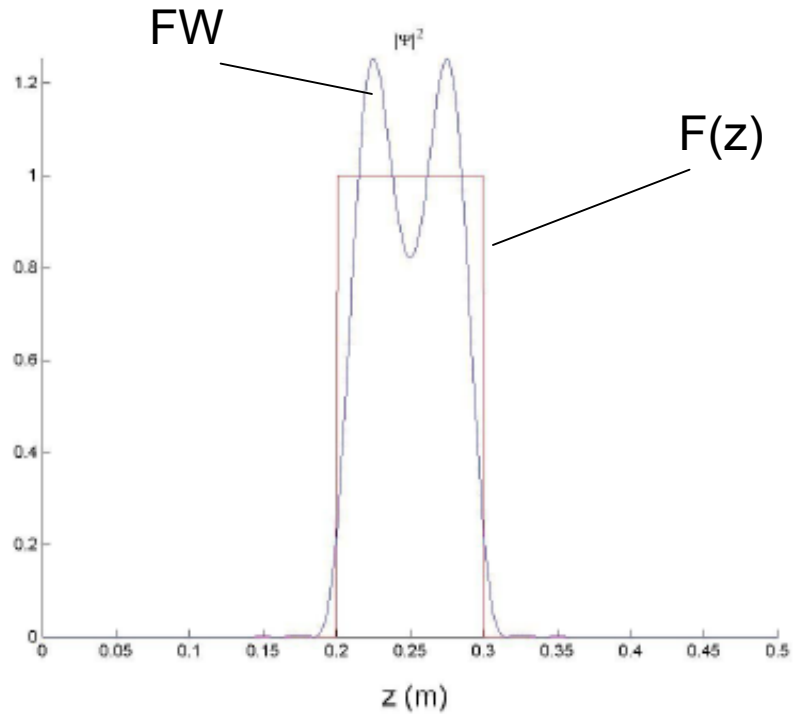

Fig. 1

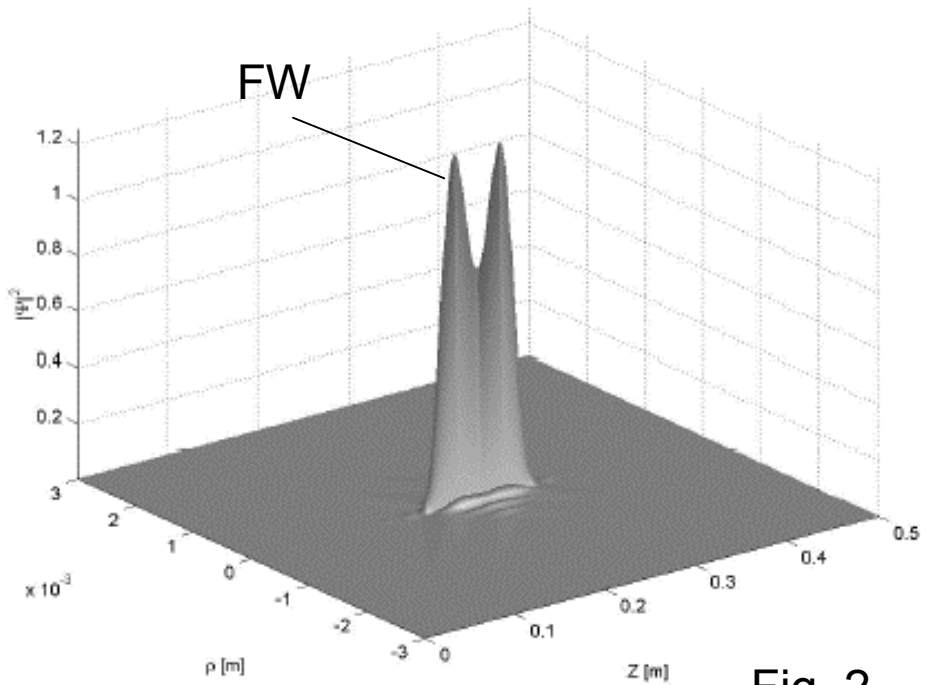

Fig. 2

2/18

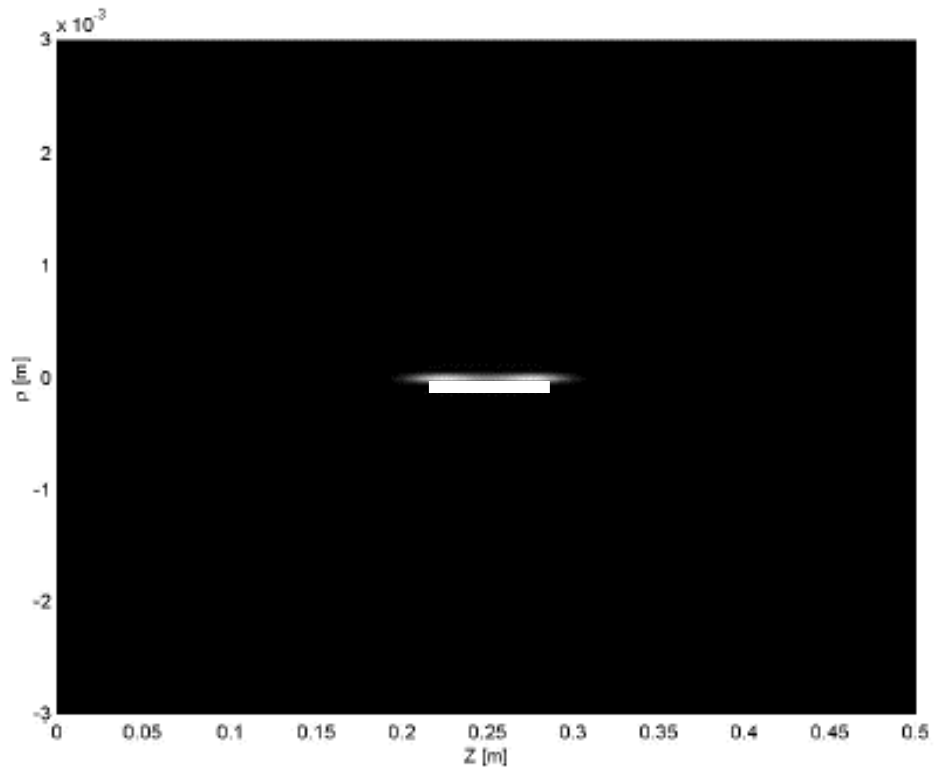

Fig. 3

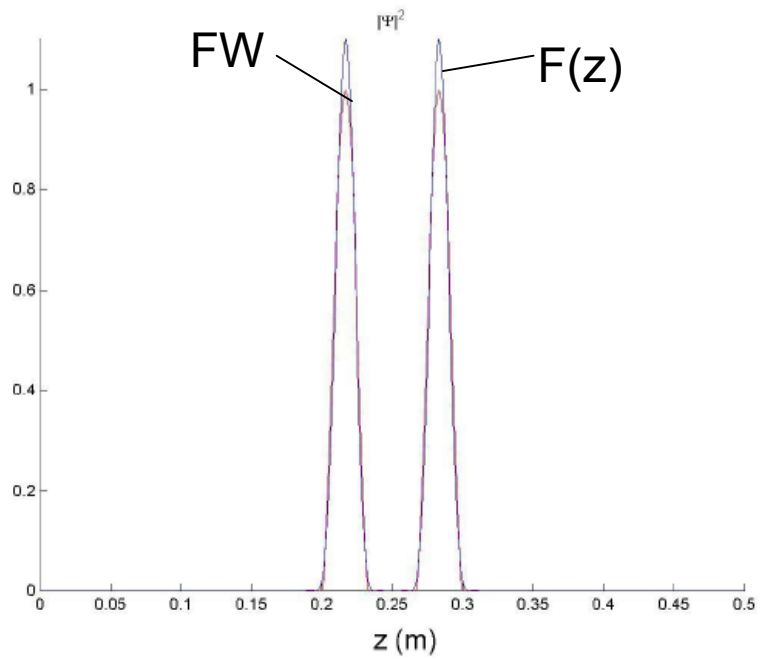

Fig. 4

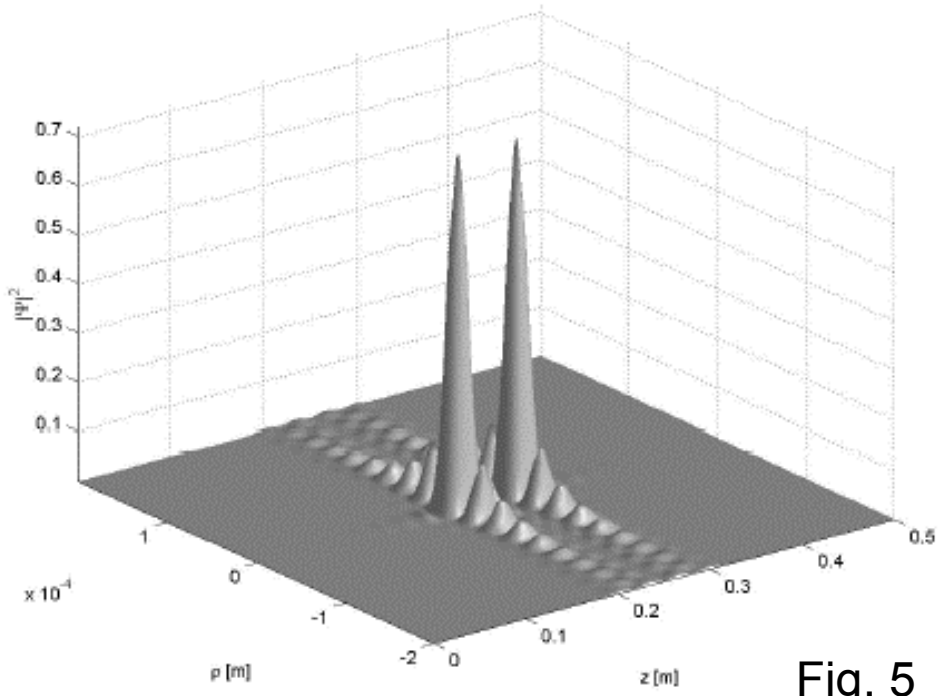

Fig. 5

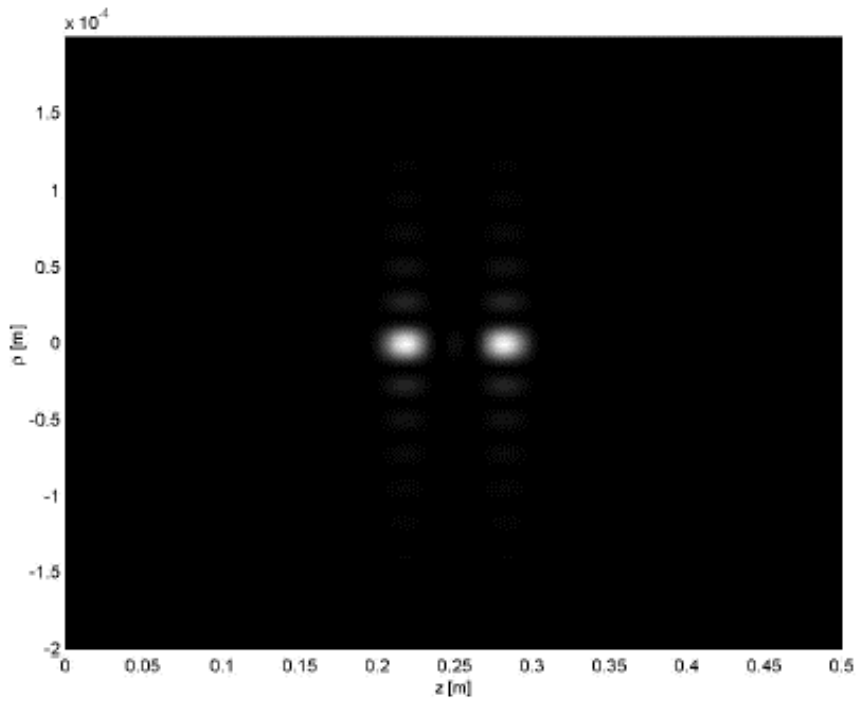

Fig. 6

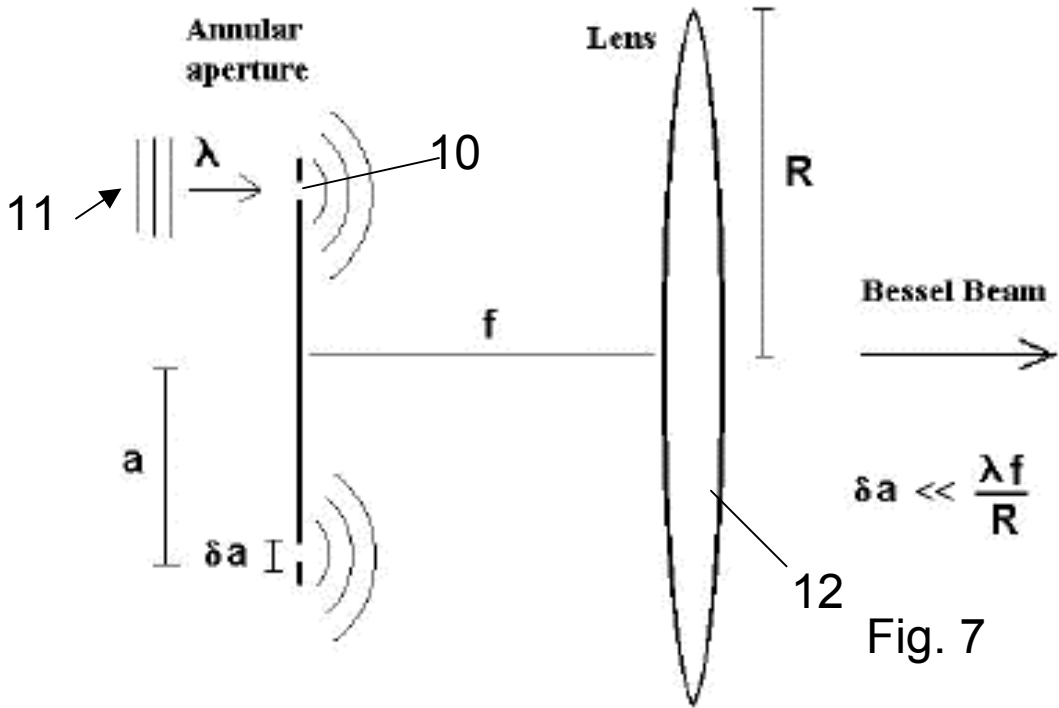

Fig. 7

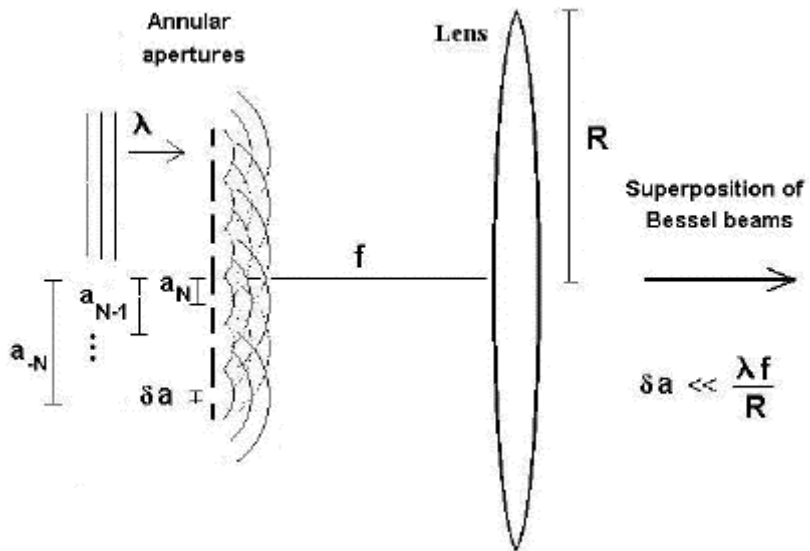

Fig. 8

5/18

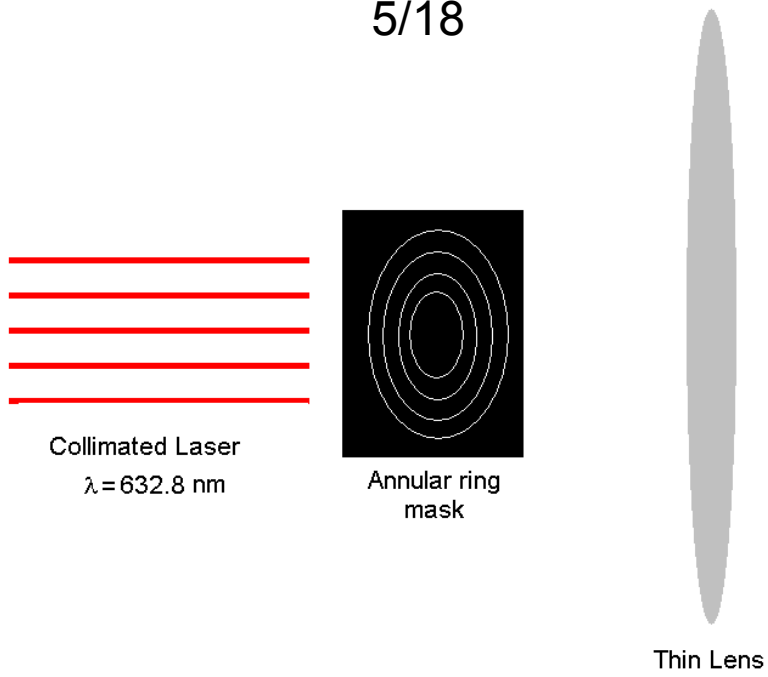

Fig. 9

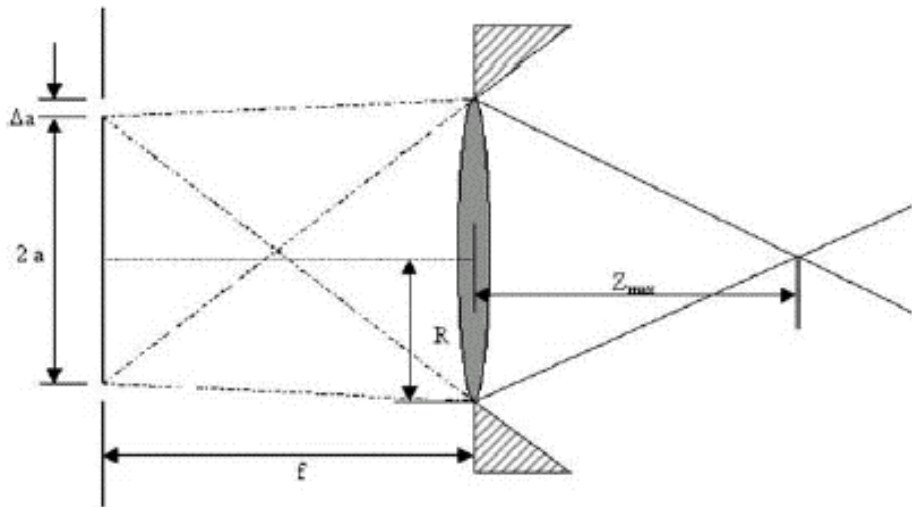

Fig. 10

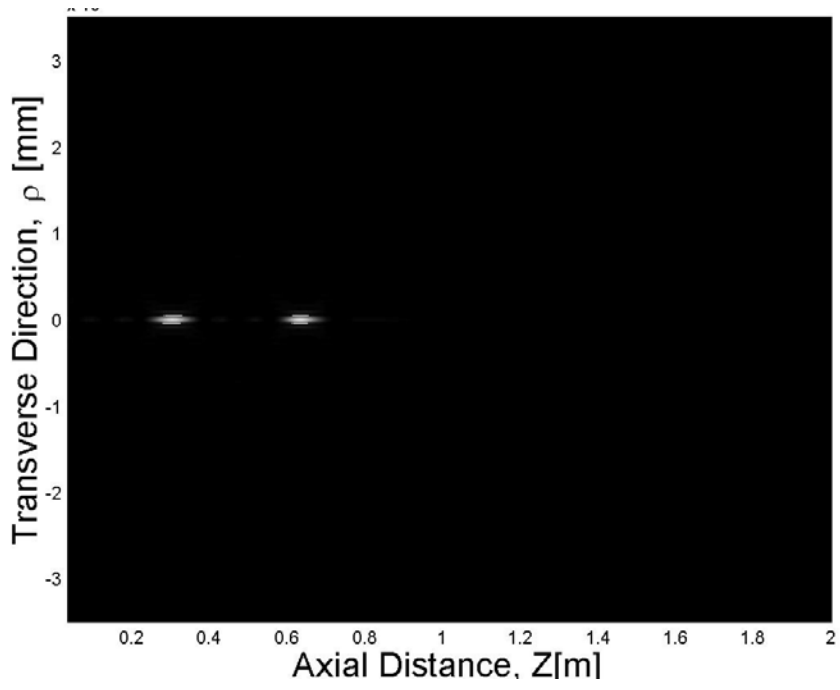

Fig. 11

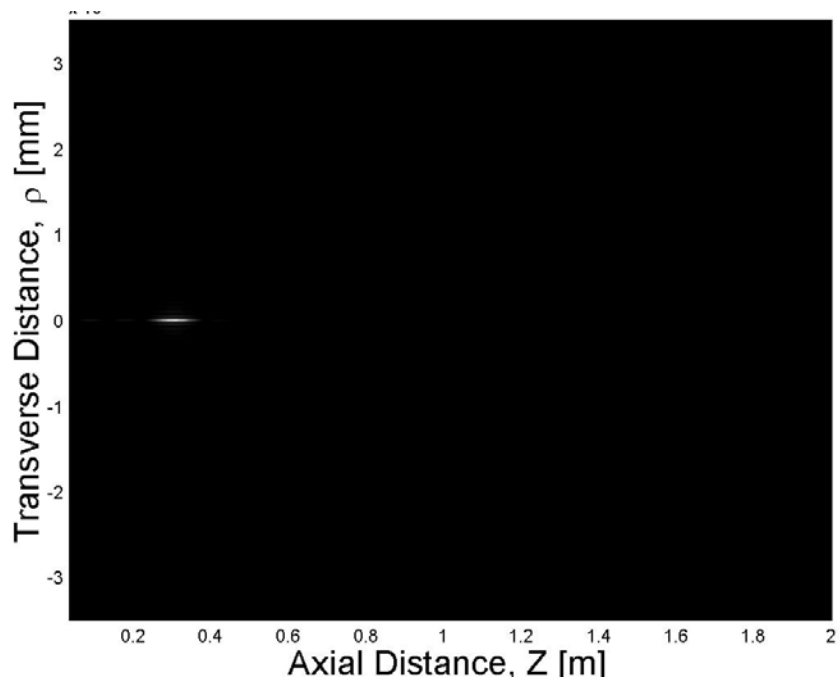

Fig. 12

7/18

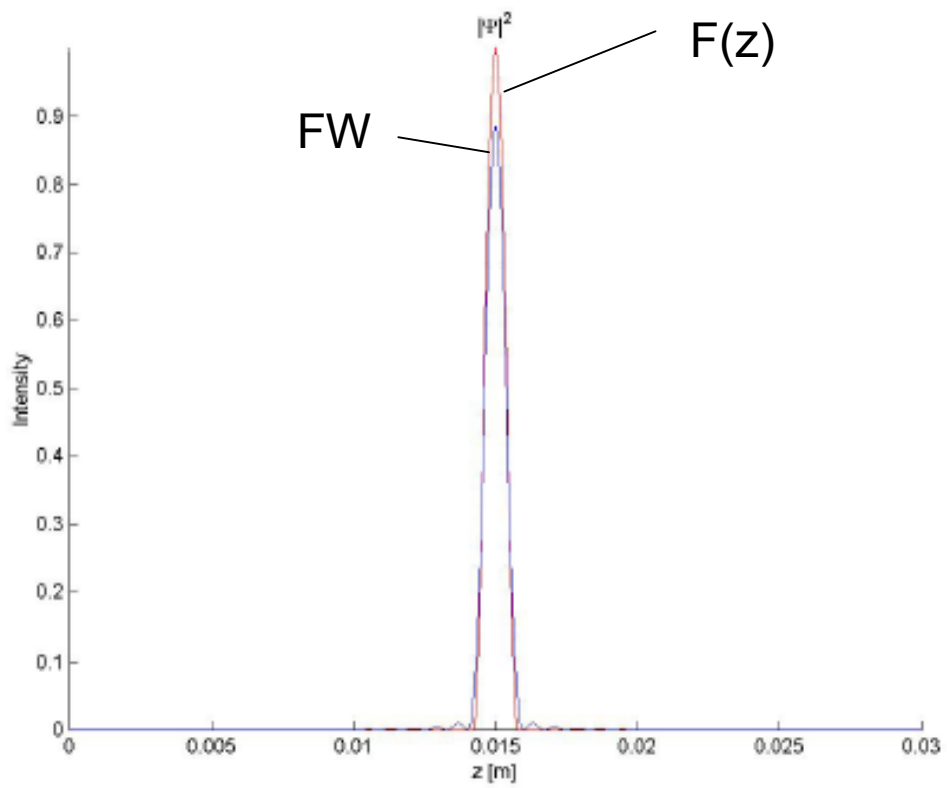

Fig. 13

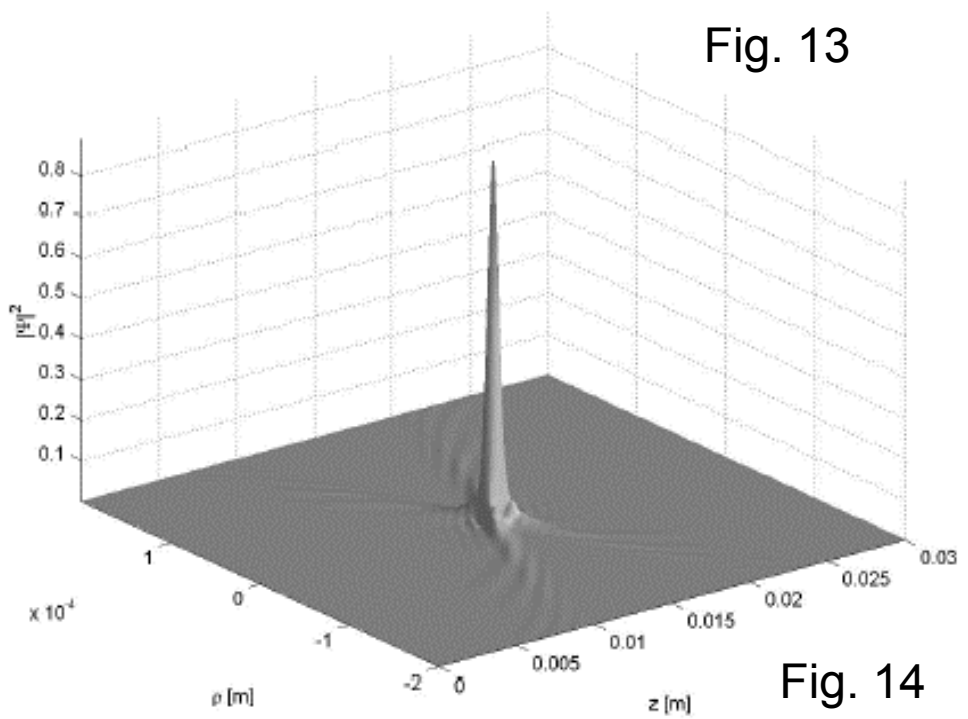

Fig. 14

8/18

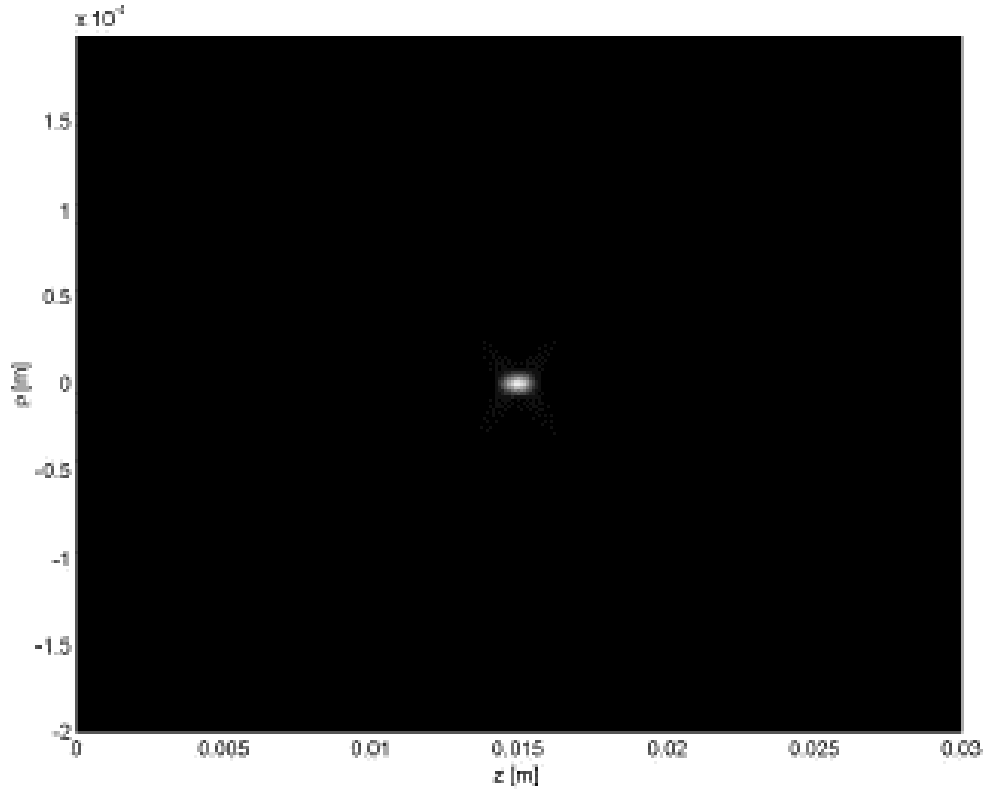

Fig. 15

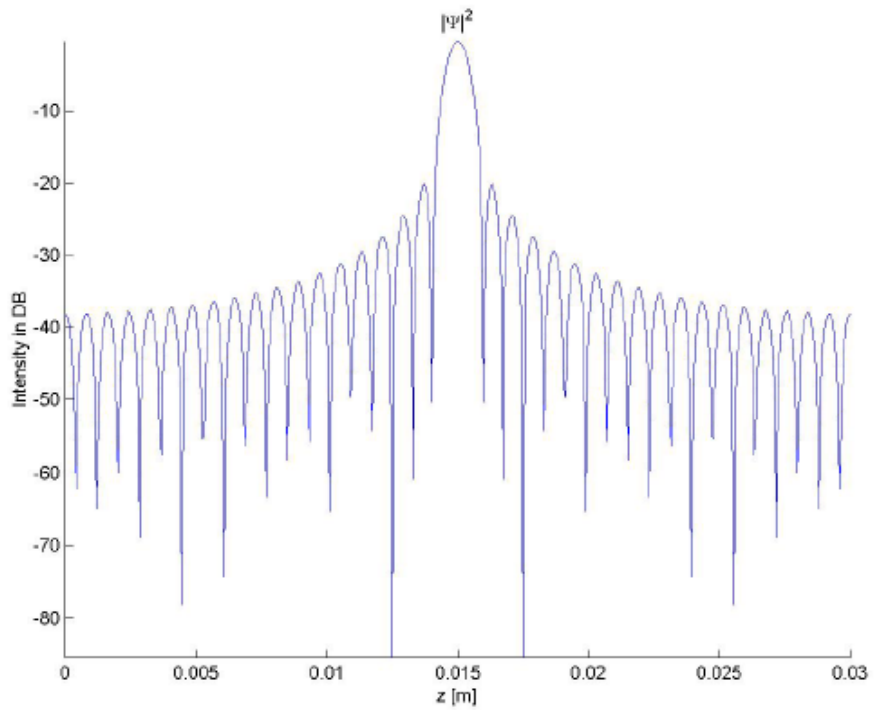

Fig. 16

9/18

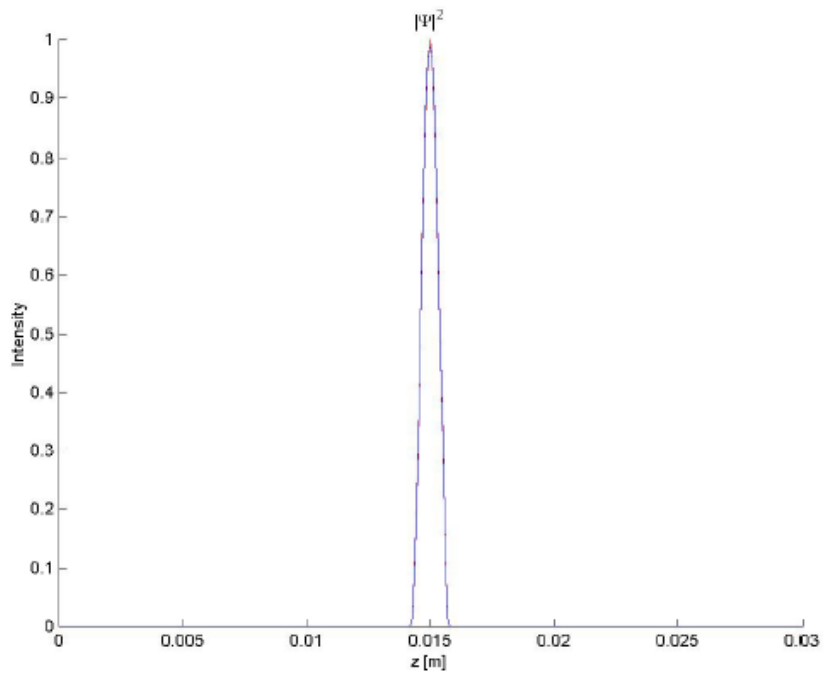

Fig. 17

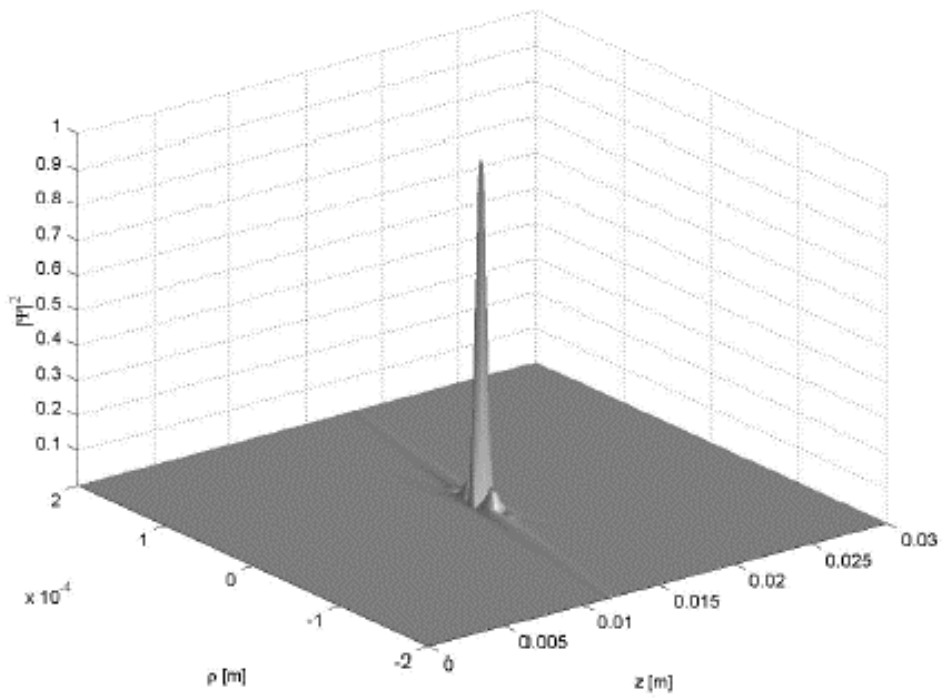

Fig. 18

10/18

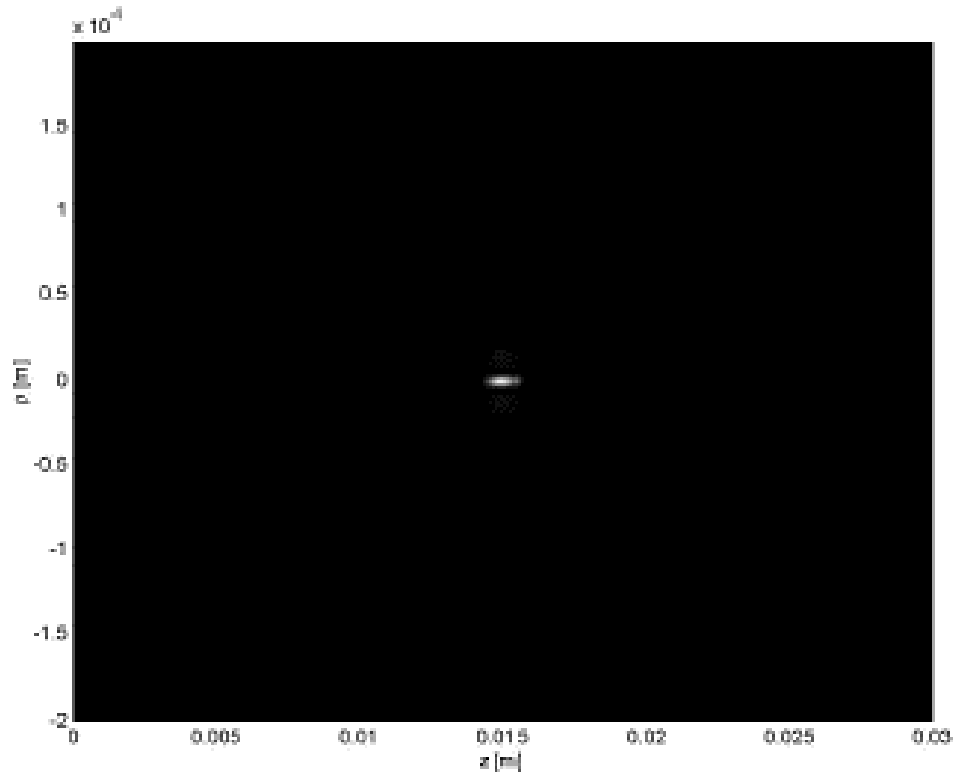

Fig. 19

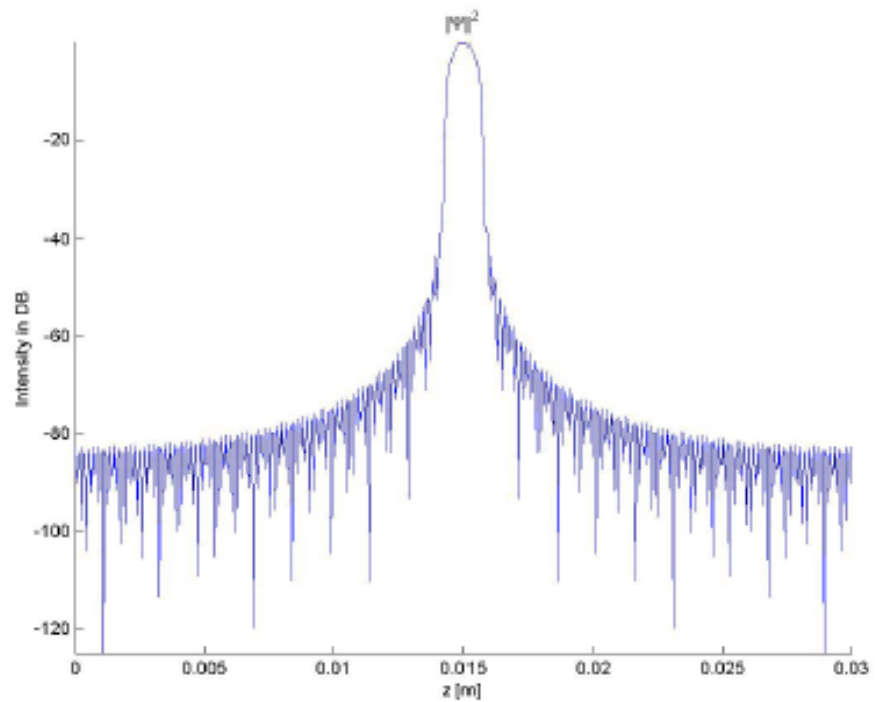

Fig. 20

11/18

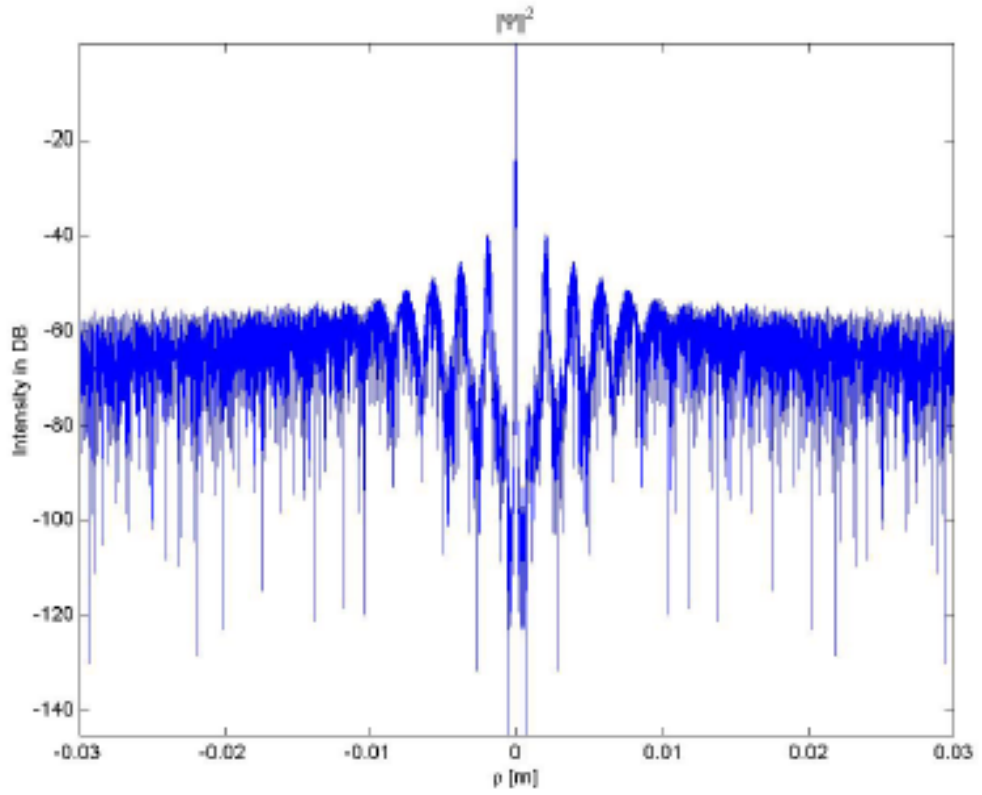

Fig. 21

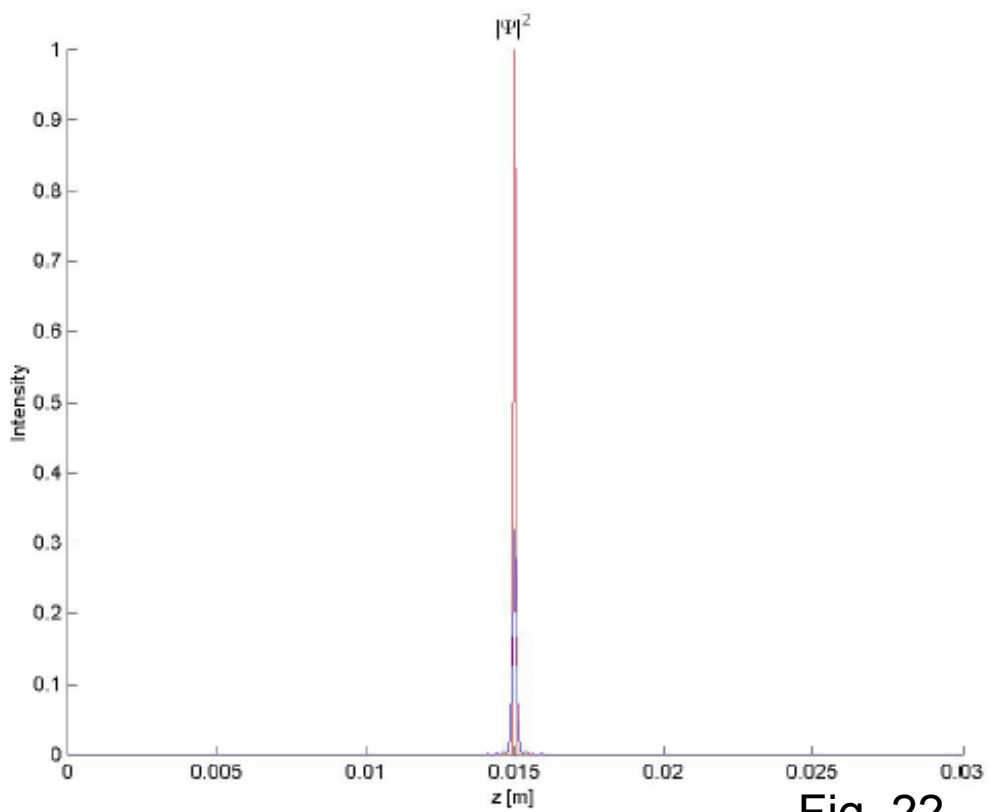

Fig. 22

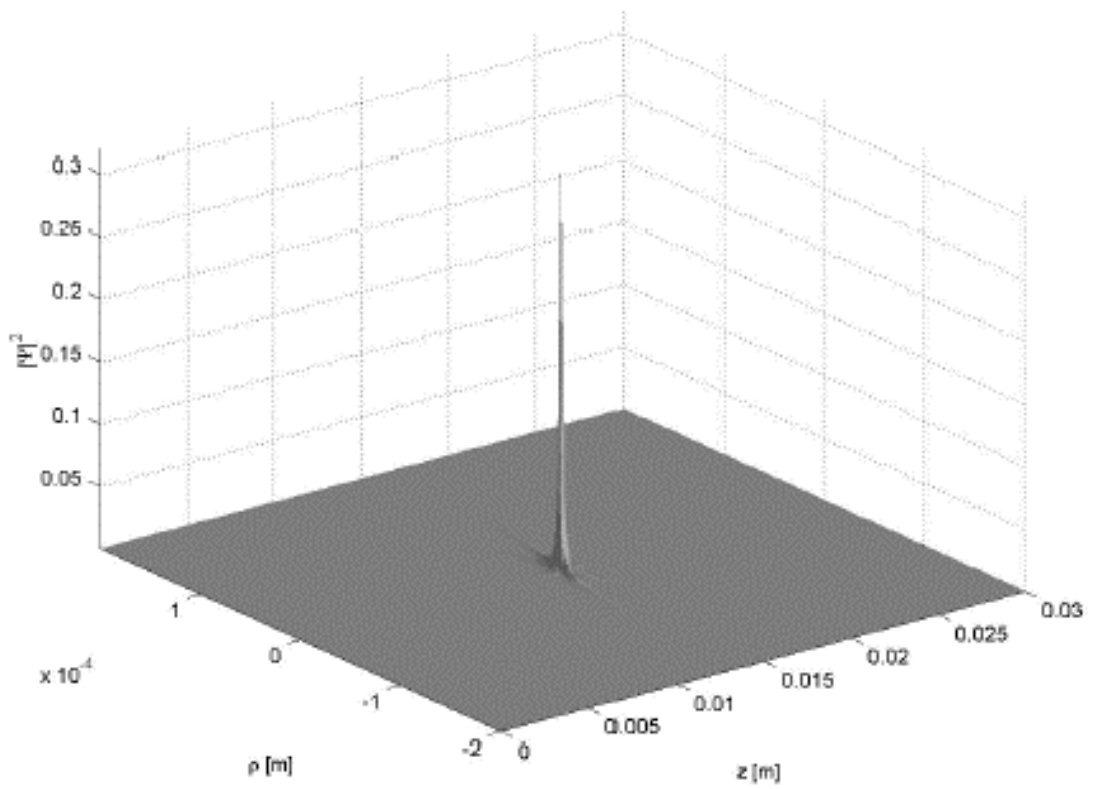

Fig. 23

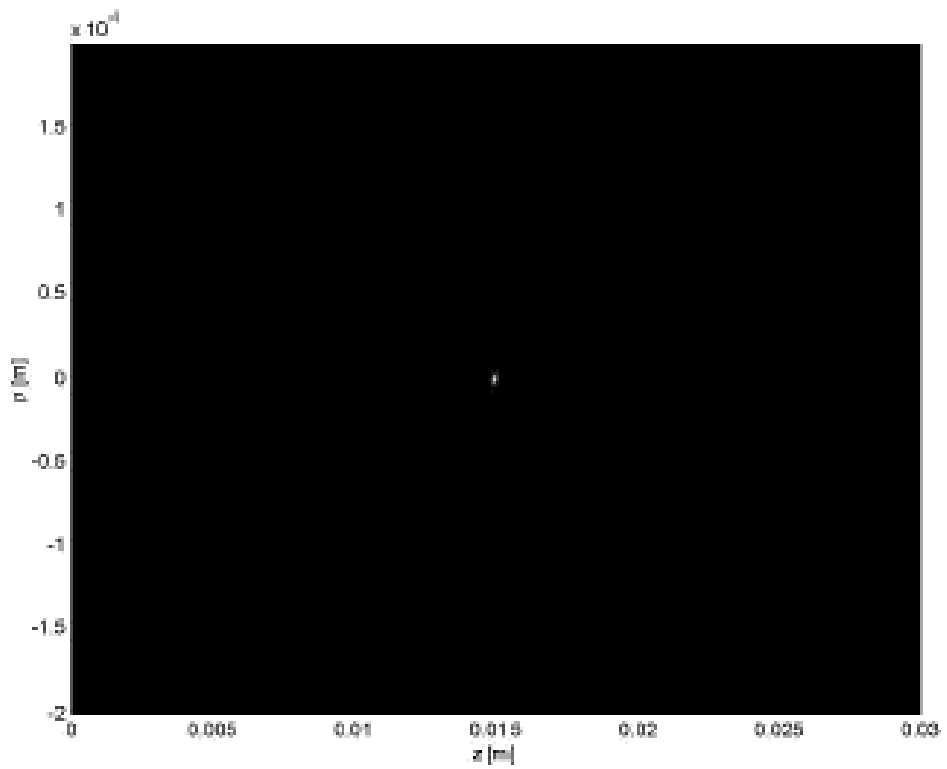

Fig. 24

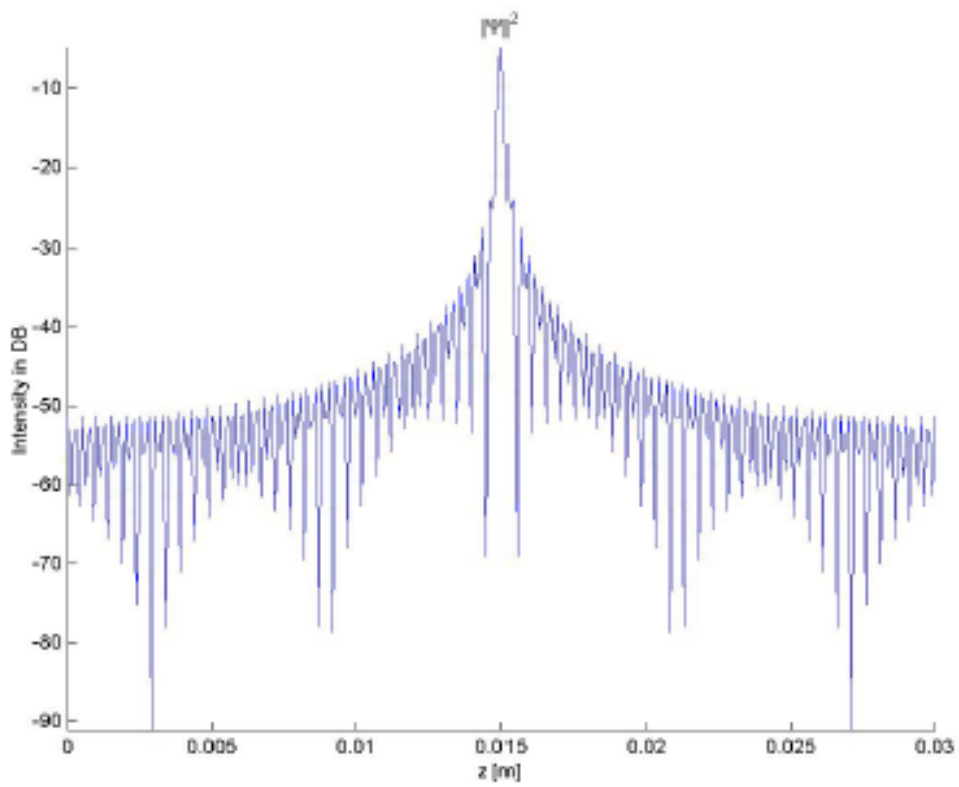

Fig. 25

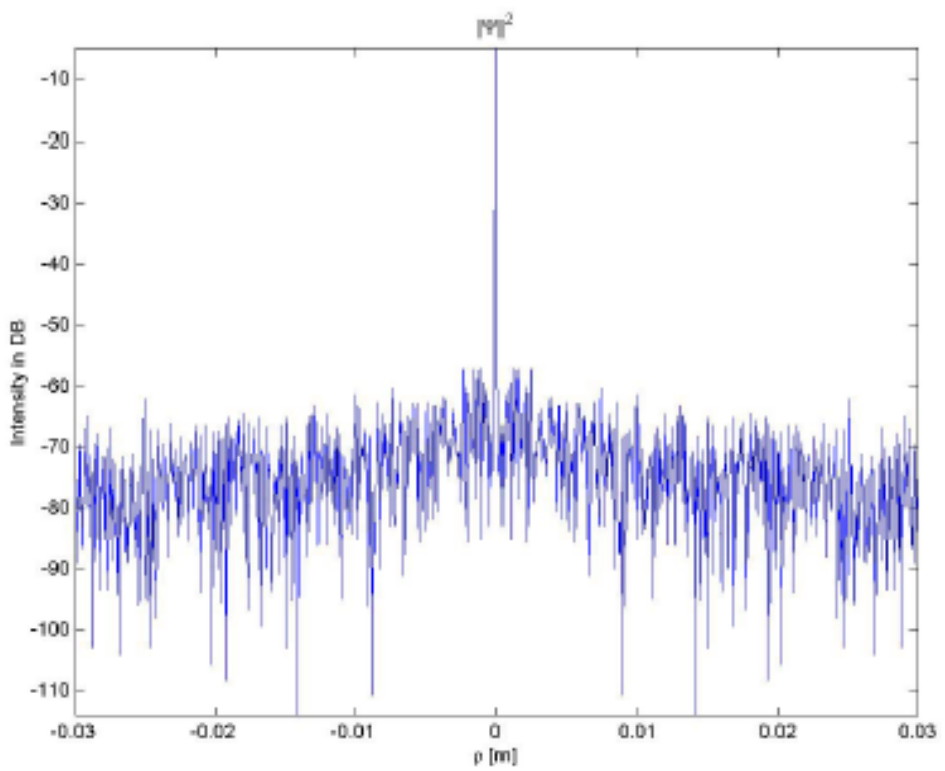

Fig. 26



Fig. 27

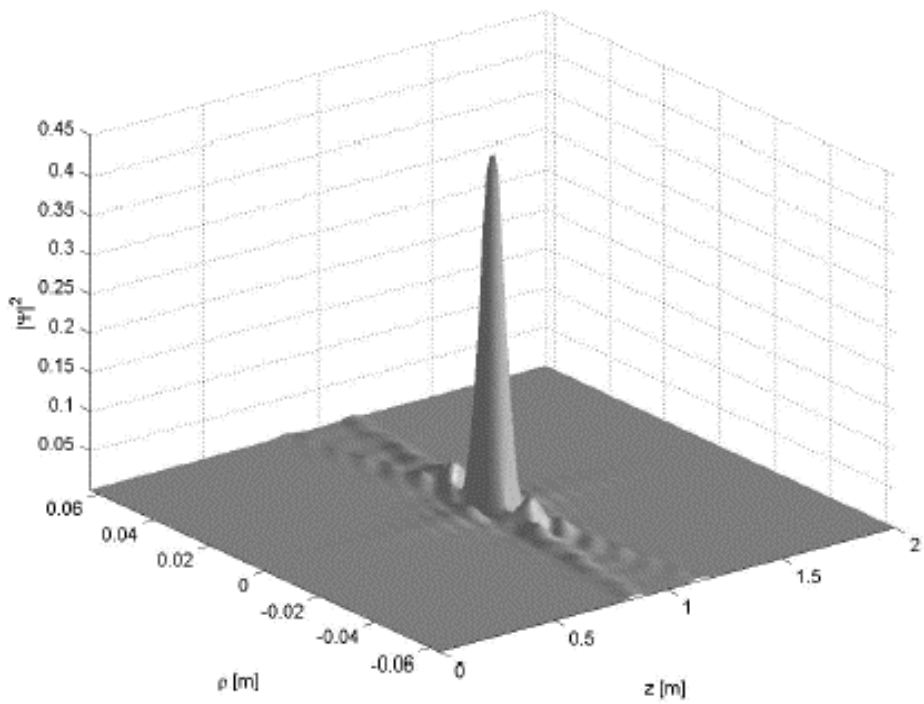

Fig. 28

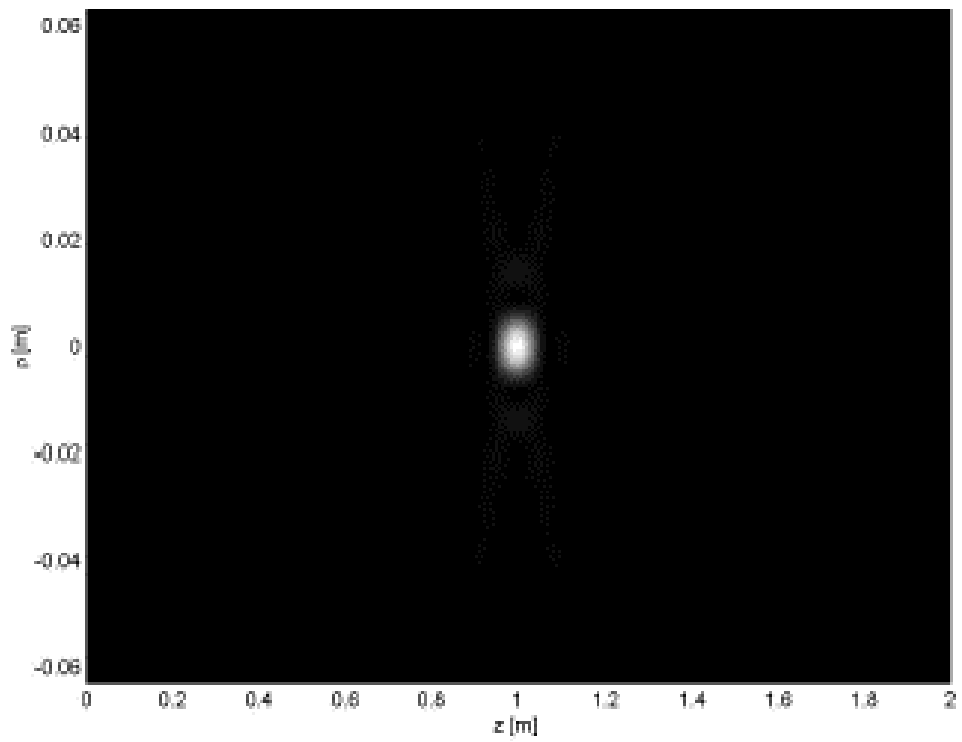

Fig. 29

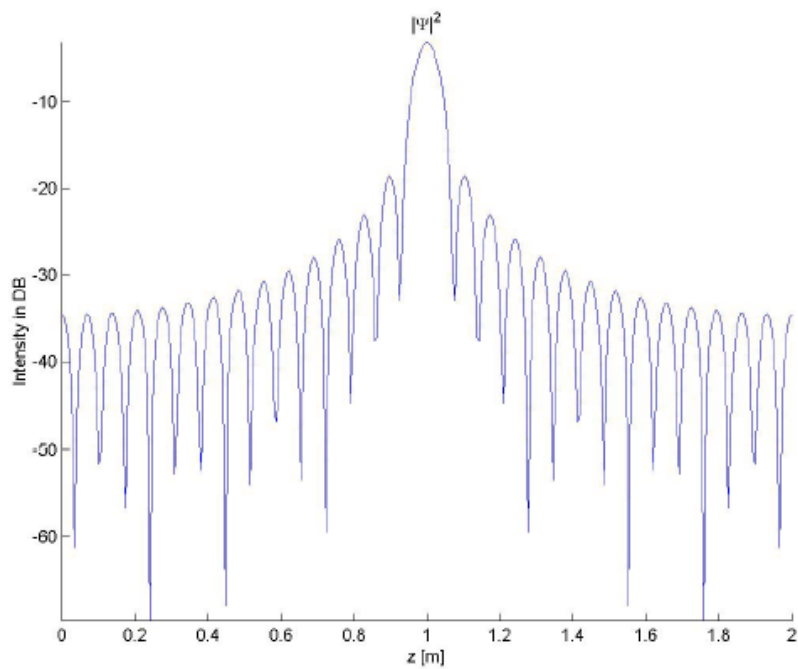

Fig. 30

16/18

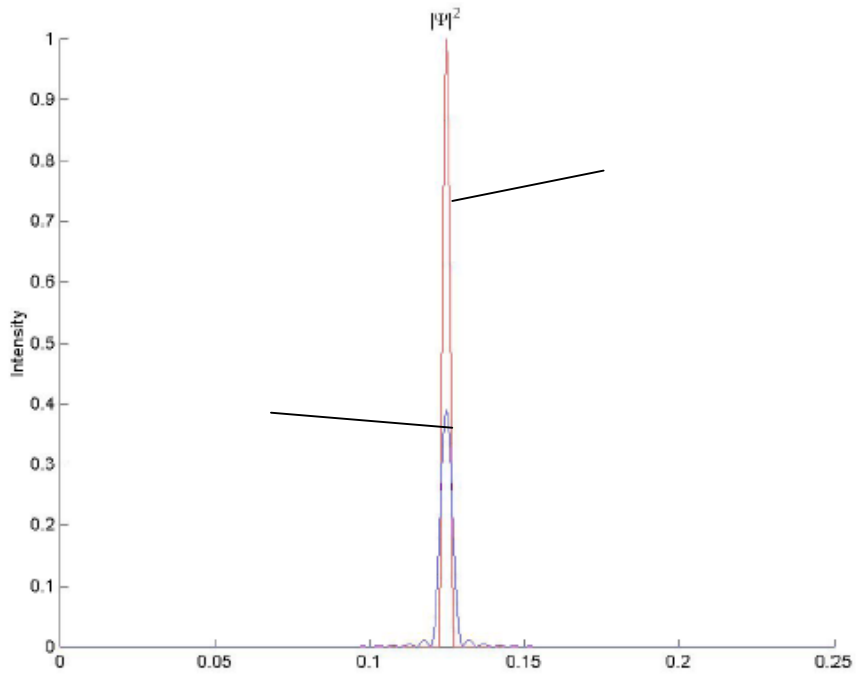

Fig. 31

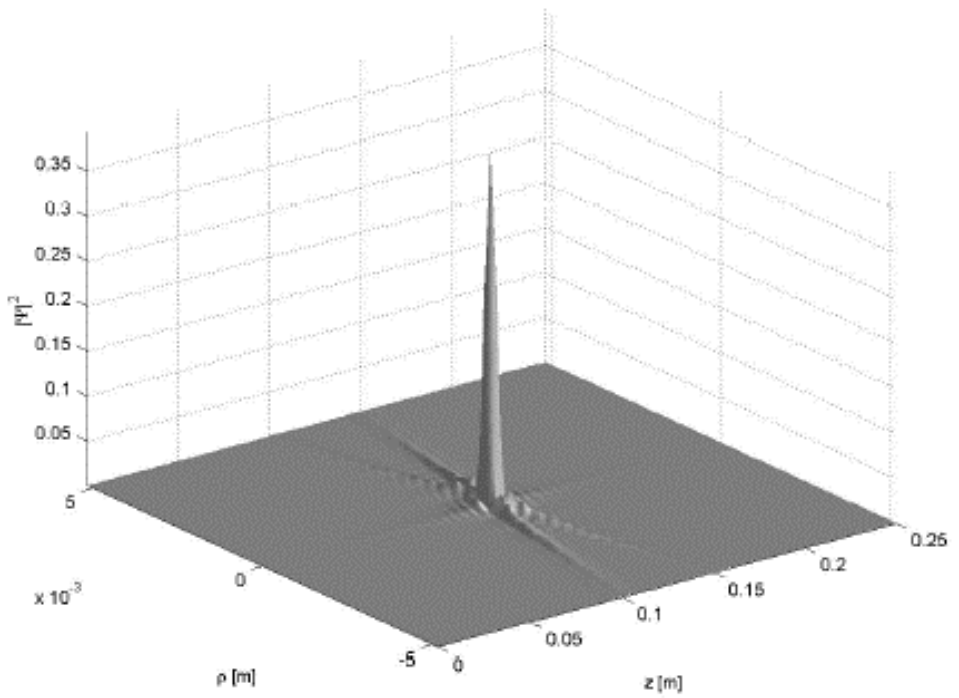

Fig. 32

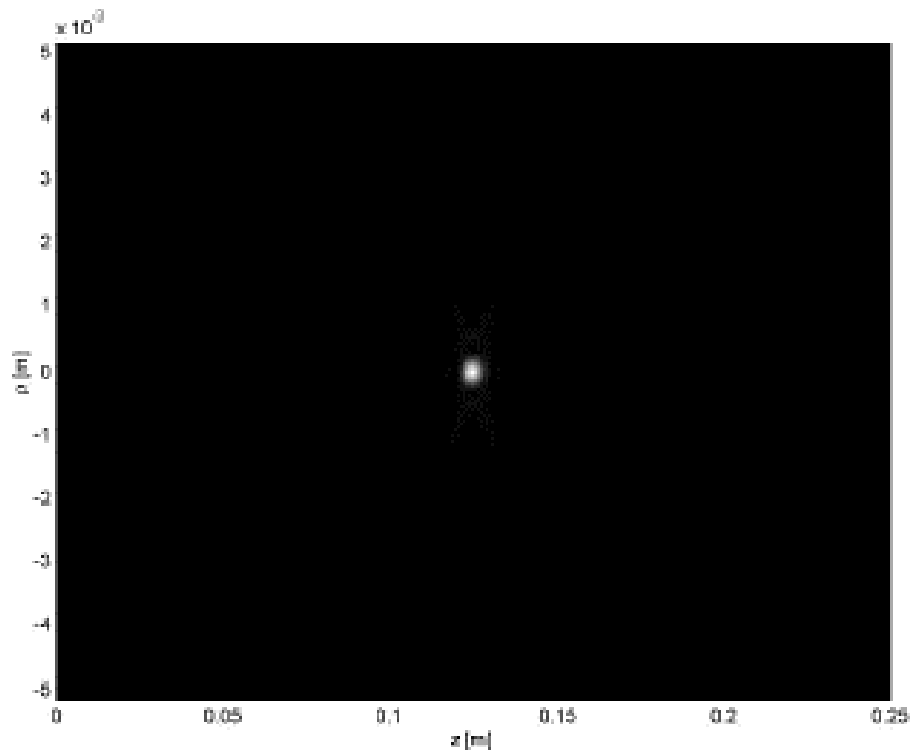

Fig. 33

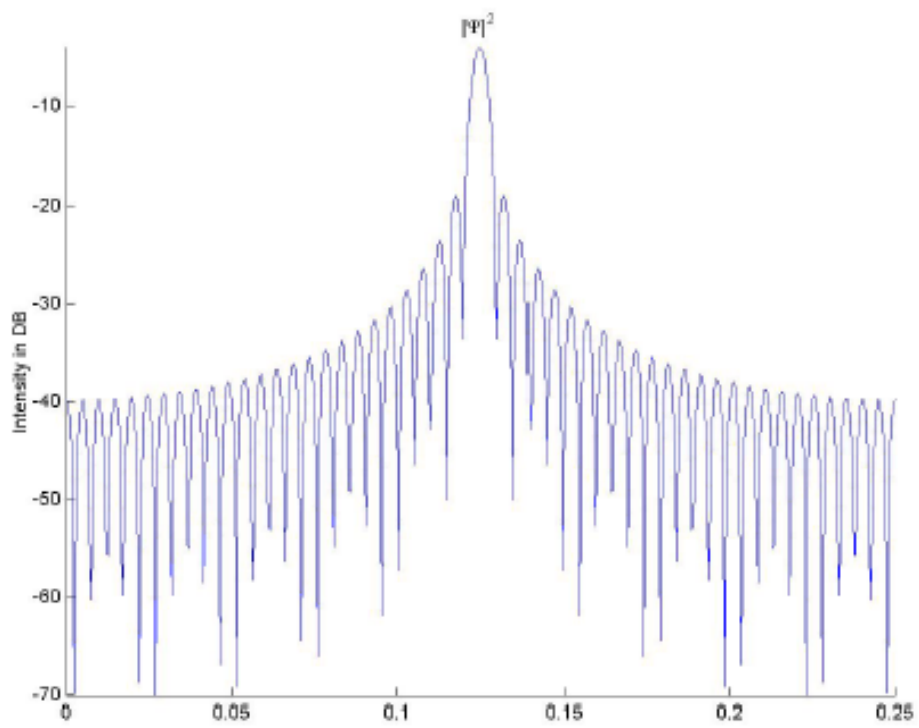

Fig. 34

18/18

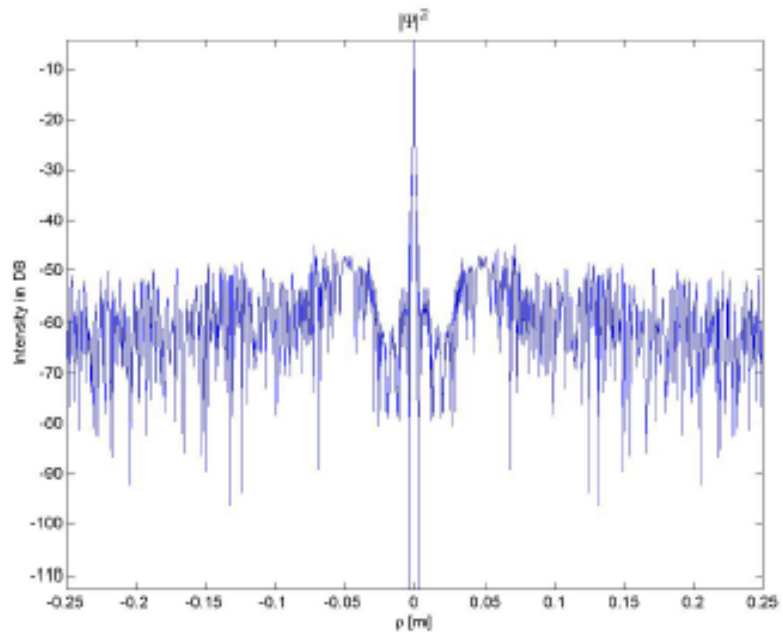

Fig. 35

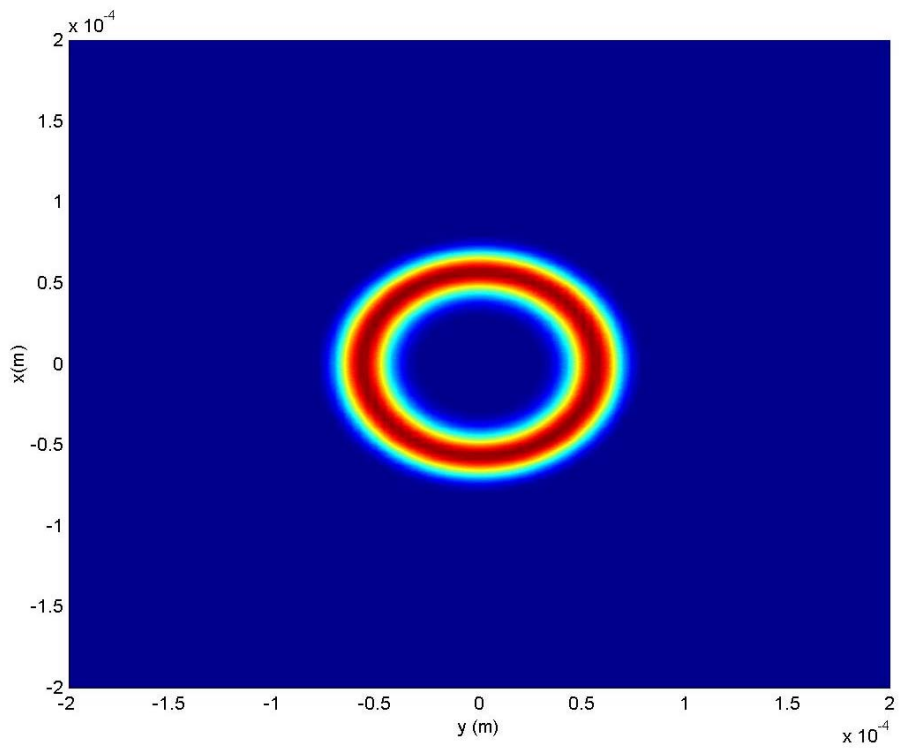

Fig. 36